

# M2M

## TAINY HMOD-V2-IO

End-to-End IP connection via mobile communications

Dr. Neuhaus Product World - July 2009



**Dr. Neuhaus**



## Introducing: TAINY HMOD-V2-IO



### Contents:

- System topologies in wireless networks
- End-to-End IP connection with the TAINY HMOD-V2-IO
- System components & accessories
- Application
- Good reasons
- Appendix





# Introduction:

## System topologies in wireless networks

## System topology: End-to-End IP connection via wireless network

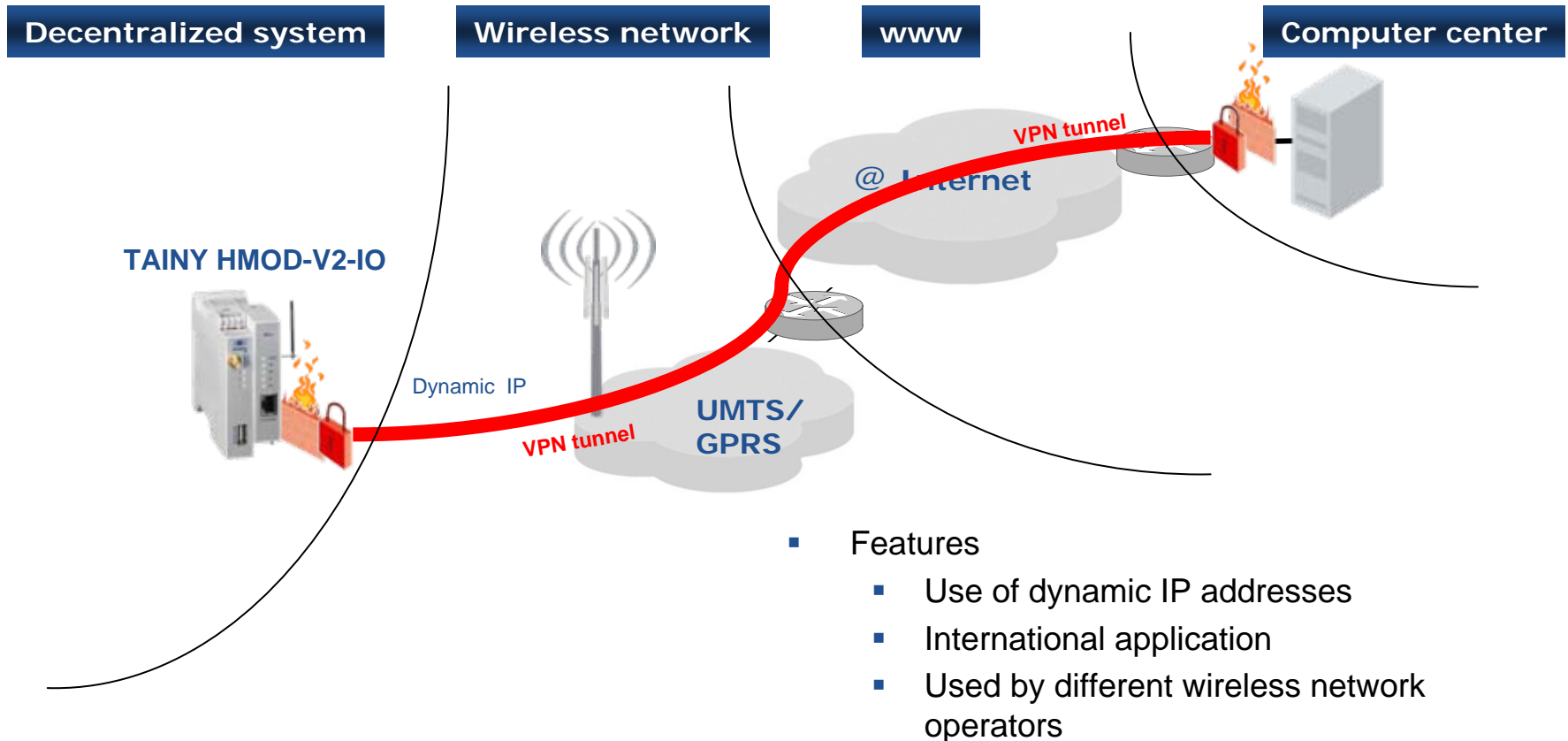
- Integration via the internet through End-to-End IP connections
  - VPN connection with IPSec protocol for confidentiality, authenticity and integrity
  - Use of “public” UMTS wireless network





# End-to-End IP connection via wireless network with the TAINY HMOD-V2-IO

## Equipped to handle any connection

- **HSDPA** VPN router and firewall combined in a single device
  - **Automatic and interruption-free** choice of the connection technology **available**
    - **HSDPA**: Up to **3.6 MBit/s** download / Up to 384 KBit/s upload;
    - **UMTS**: Up to 384 KBit/s download & upload
    - **EDGE (EGPRS)**: Class 10; up to 237 KBit/s download / up to 118 KBit/s upload;
    - **GPRS**: Class 10; up to 85.6 KBit/s download / up to 42.8 KBit/s upload;
  - **Dial-up option** via **GSM/CSD for remote configuration**  
non-transparent 2.4, 4.8, 9.6, 14.4kbps; SMS (TX): Point-to-point
- Frequency bands for **international use**
  - Quad-band: GSM 850/900/1800/1900 MHz
  - Tri-band: UMTS/HSDPA (WCDMA/FDD) 850/1900/2100 MHz
- Antenna connection
  - Nominal impedance: 50 ohms; jack: SMA
  - Diverse antennas available; depending on requirement and installation location
- Application interface
  - **10/100 Base-T** (RJ45 jack); Ethernet IEEE802; 10/100 Mbit/s; **Auto Cross Over**

## Consistent data confidentiality and integrity

- HSDPA **VPN router** and firewall combined in a single device
  - The TAINY HMOD-V2-IO connects **the local network with a remote network** via a VPN tunnel. The IP data packets exchanged between the two networks are **encrypted** and are protected against unauthorized manipulation by the **VPN tunnel**. Thus, sensitive data can be transported **bi-directionally** through such public networks as the internet without jeopardizing data **confidentiality** or **integrity**.
    - Protocol: **IPSec** (tunnel and transport mode)
    - Encryption: **3DES, AES, DES**
    - **Packet authentication**: MD5, SHA-1
    - **Internet Key Exchange** (IKE)
    - Authentication: **Pre-Shared Key (PSK), X.509v3 certificates**

## The “firewall” – Protection from attacks

- HSDPA router with **firewall** combined in a single device
  - The TAINY HMOD-V2-IO is equipped with firewall functions **to protect** the local network and itself from attacks from the outside:
    - As a dynamic packet filter, the **Stateful Inspection Firewall** examines data packets on the basis of the original and the destination address. Data packets that cannot be allocated to specific criteria or that might belong to a DoS attack are rejected.
    - And **anti-spoofing** blocks undesired data traffic
    - **Port forwarding**: Depending on the configuration, it is possible to forward the data traffic coming in at certain ports to defined IP addresses (devices) in the local network connected, e.g. data from Port 4711 always goes to 172.25.15.222

## High availability and stable connections

- Intelligent **connection monitoring**
  - **Monitoring** of the availability of the **internet/intranet connection**
    - Dispatch of ping packets (ICMP) to up to **four receivers** in the external network
    - **Time interval** for connection check and **number** of failed attempts **can be adjusted**
    - **Action** for defective connection **can be selected** from between
      - **Renew** UMTS/GPRS connection
      - **Restart** device
  - Monitoring of the **IPSec** connection
    - Check of an IPSec connection using a **dead peer detection** inquiry
    - **Time interval** for connection check and **number** of failed attempts **can be adjusted**
  - 24h reset; time can be selected freely

## To be on the safe side

- Dispatch of an **alarm text message** via GSM network
  - 2 different **events**
    - Signal of incoming message,
    - no UMTS/GPRS connection made
  - Entry of own **call numbers** and free **text** on each of the two events
- Incoming message
  - Connection of a digital sensor (e.g. door switch)
  - **Galvanic** separation between the TAINY HMOD and the application, input voltage 5...30V
- Outgoing message
  - **Signal sent** when a VPN tunnel is set up
  - **Potential-free**;  $U_{Max} = 30V$ ;  $I_{Max} = 20mA$



I1+ I1- O1a O1b

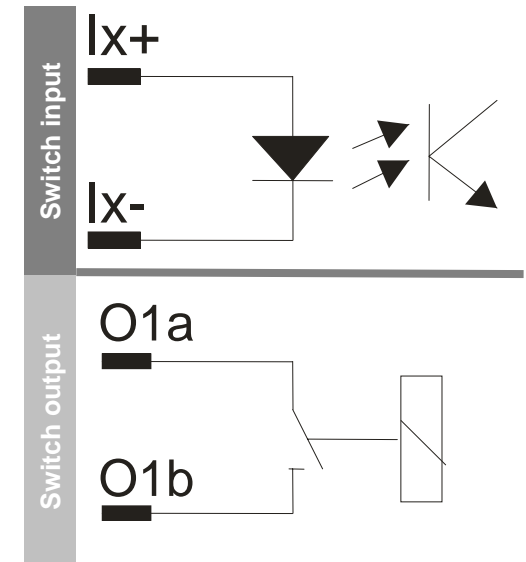

## Not limited to industrial applications

- **Large** input voltage range:
  - Voltage: 12-60 VDC
  - Power input:  $I_{In}$  365 - 92mA;  $I_{Burst}$  1.26A at full transmitting power  
Power consumption <sub>(typical)</sub>: 4-4 W @ 12 V, 4.0 W @ 24 V, 5.5 W @ 60 V
- **Large** temperature range:
  - Operation from -20 °C to +60 °C; humidity 0-95 %, non-condensing
- **Mechanics**
  - **Top-hat rail** mounting
  - Plastic enclosure; protection type/class: IP20
  - Dimensions: approx. 114.5 x 45 x 99 mm (L x W x H)
  - Weight: approx. 280 g
  - SIM card
    - accessible **from the outside**
    - but nevertheless **protected** from direct access

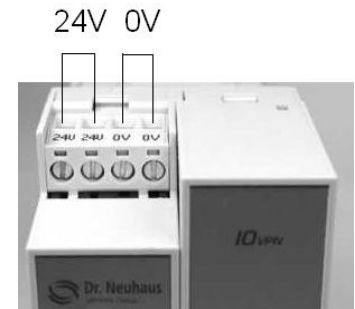



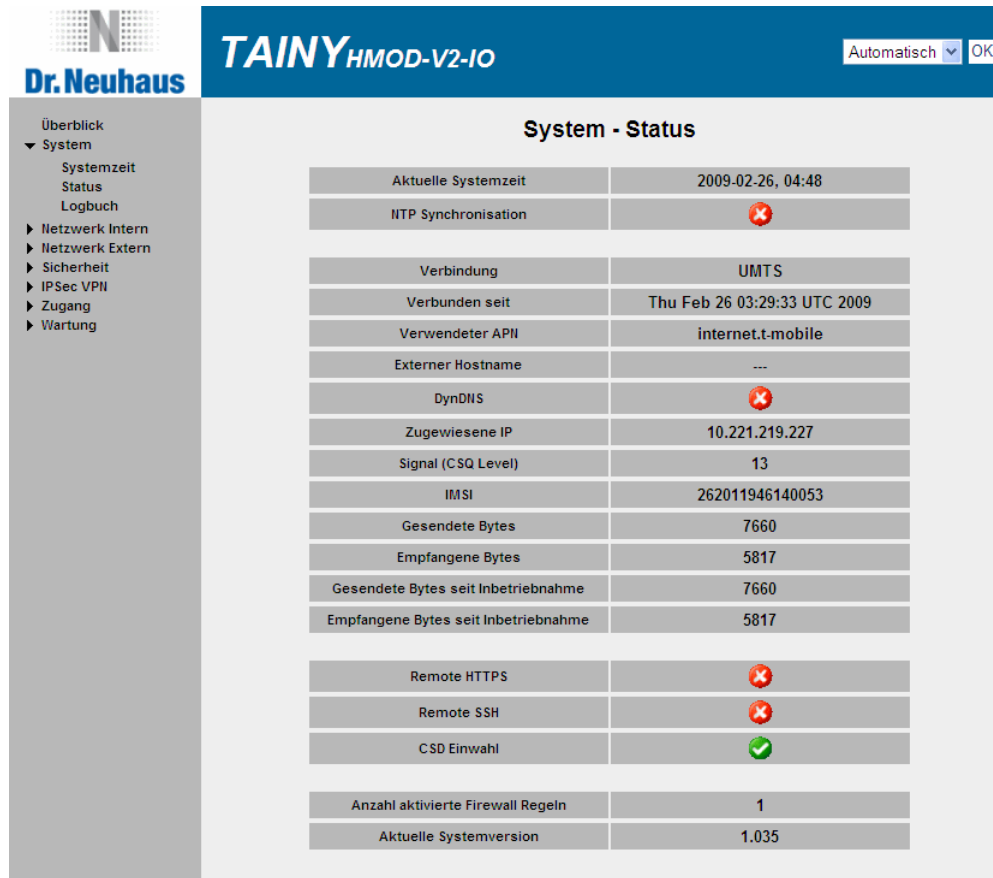

## Everything via remote control

- Easy configuration of all functions on WEB interface
- Also accessible via GSM/CSD, even when there is no data connection



The screenshot shows the web interface for the TAINY HMOD-V2-IO device. The page title is "System - Status". On the left, there is a navigation menu with options like "Überblick", "System", "Systemzeit", "Status", "Logbuch", "Netzwerk Intern", "Netzwerk Extern", "Sicherheit", "IPSec VPN", "Zugang", and "Wartung". The main content area displays a table of system parameters and their current status.

System - Status	
Aktuelle Systemzeit	2009-02-26, 04:48
NTP Synchronisation	
Verbindung	UMTS
Verbunden seit	Thu Feb 26 03:29:33 UTC 2009
Verwendeter APN	internet.t-mobile
Externer Hostname	...
DynDNS	
Zugewiesene IP	10.221.219.227
Signal (CSQ Level)	13
IMSI	262011946140053
Gesendete Bytes	7660
Empfangene Bytes	5817
Gesendete Bytes seit Inbetriebnahme	7660
Empfangene Bytes seit Inbetriebnahme	5817
Remote HTTPS	
Remote SSH	
CSD Einwahl	
Anzahl aktivierte Firewall Regeln	1
Aktuelle Systemversion	1.035

## Everything via remote control

- **Secure remote access** to the TAINY HMOD via SSH and HTTPS
  - **System status**
    - Connection: Indicates whether and which **wireless connection** is in effect
    - Allocated **IP address**: Indicates the IP address of the TAINY HMOD in the UMTS/GPRS
    - Signal (CSQ level): Indicates the **strength of the wireless signal** as CSQ value
    - **Bytes sent/bytes received**: Indicates the number of bytes sent or received in the UMTS/GPRS network
  - **Logbook**
    - **Important events** in the operating process are stored in the logbook: e.g.: reboot, changes in the configuration, connection dial-ups, connection interruptions, signal strength, ...
    - The logbook can be sent to an FTP server **automatically** once a day via FTP (= File Transfer Protocol).
  - **Updates**
    - New device software can be uploaded **immediately** or at any **previously specified time**

## Compliance

- CE
- R&TTE (GSM) - Guideline 99/05/EC Standard used: EN301 511 v.9.0.2
- HSDPA/UMTS/ GSM/EGPRS Module - GCF, PTCRB
- EMV/ESD - Guideline 2004/108/EG Standards used: EN 55022:2006 Class A, EN 55024: 1998 + A1:2001 + A2:2003, EN 61000-6-2:2001
- Electrical safety - Guideline 2006/95/EG Standard used : EN 60950-1:11-2006
- Environment - The device complies with the European ROHS and WEEE guidelines.

# System Components & Accessories

## System components for operation

- Antenna
  - Antenna, adjusted to the frequency bands of the GSM network operator you have selected: 850 MHz, 900 MHz, 1800 MHz, 1900 MHz or 2100 MHz.
  - We recommend the use of antennas we have approved – see [Accessories for the TAINY HMOD-V2-IO](#).
  
- Power supply
  - A power supply with a voltage of between 12 VDC and 60 VDC that can deliver enough power
  - The nominal power consumption is approximately 365 mA at 12V and 92 mA at 60V.
  
- SIM card
  - Prepared for HSDPA / UMTS / EGPRS / GPRS  
The SIM card should be prepared by the GSM network operator for the following data services: HSDPA, UMTS, EGPRS, GPRS.
  - Connection with dial-up via GSM/CSD  
The SIM card has to be prepared by your wireless network operator for CSD service, if you want to take advantage of remote access via a data dial-up connection.

## Accessories for the TAINY HMOD-V2-IO

Product, designation	Article number
Wall power supply SA07 100-240 VAC/24VDC 1A	316459
Top-hat rail power supply DR45 85-265VAC/24VDC 2A	316411
Dual-band device antenna (900/1800 MHz) Mounted directly on device; Gain -5 dB, SMA connection	316213
Tri-band flat antenna (900/1800/1900 MHz) Mounting location: Indoor/outdoor; Gain: 0dB, Connection: SMA, cable length: 3m	316220
Dual-band rod antenna (900/1800 MHz) Mounting location: Indoor, clip fastening; Gain: 2dB, Connection: SMA, cable length: 1.5m	316237
Tri-band rod antenna (900/1800/1900 MHz) Mounting location: In/outdoor, bracket fastening; Gain: 2dB; Connection: SMA, cable length: 5m	316244
Antenna adapter, SMA - FME	316299
Antenna adapter, SMA - SMA, 90° angled	316442
Serial connection cable RJ45 <-> DB9 0.5m	316268

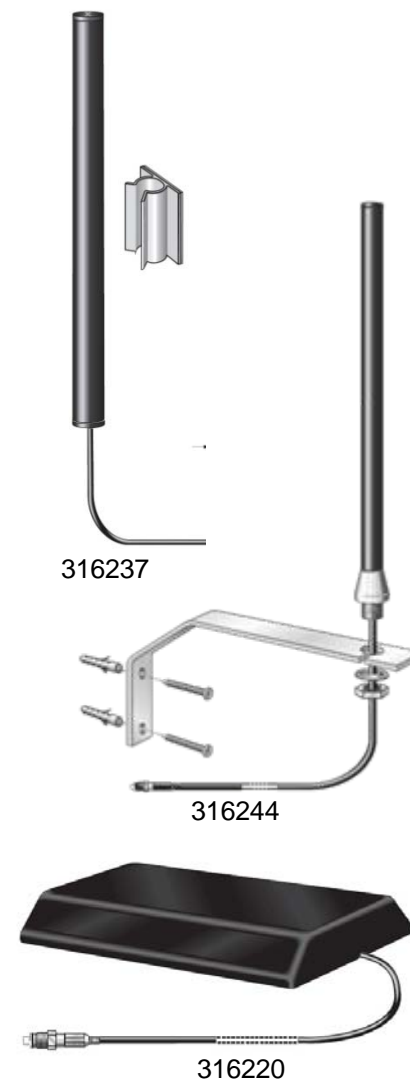

# Applications

## Remote management – Wireless transmitter stations

- Customer requirement:
  - Remote monitoring of DVB-T transmitting and intermediate stations
  
- Previously:
  - Transmitting stations were connected primitively via leased line or dial-up connection.
  - No uniform, continuous monitoring
  
- Requirement:
  - Uniform, continuous monitoring
  - Malfunction monitoring
  - Integration in existing infrastructure
  
- Customer's decision:
  - Use of a wireless router with VPN security functionality



## Remote management – Wireless transmitter stations

- Secure LAN 2 LAN link-up via VPN tunnel
- Dynamic delivery of the IP address
- Independent monitoring of the GPRS and VPN connection

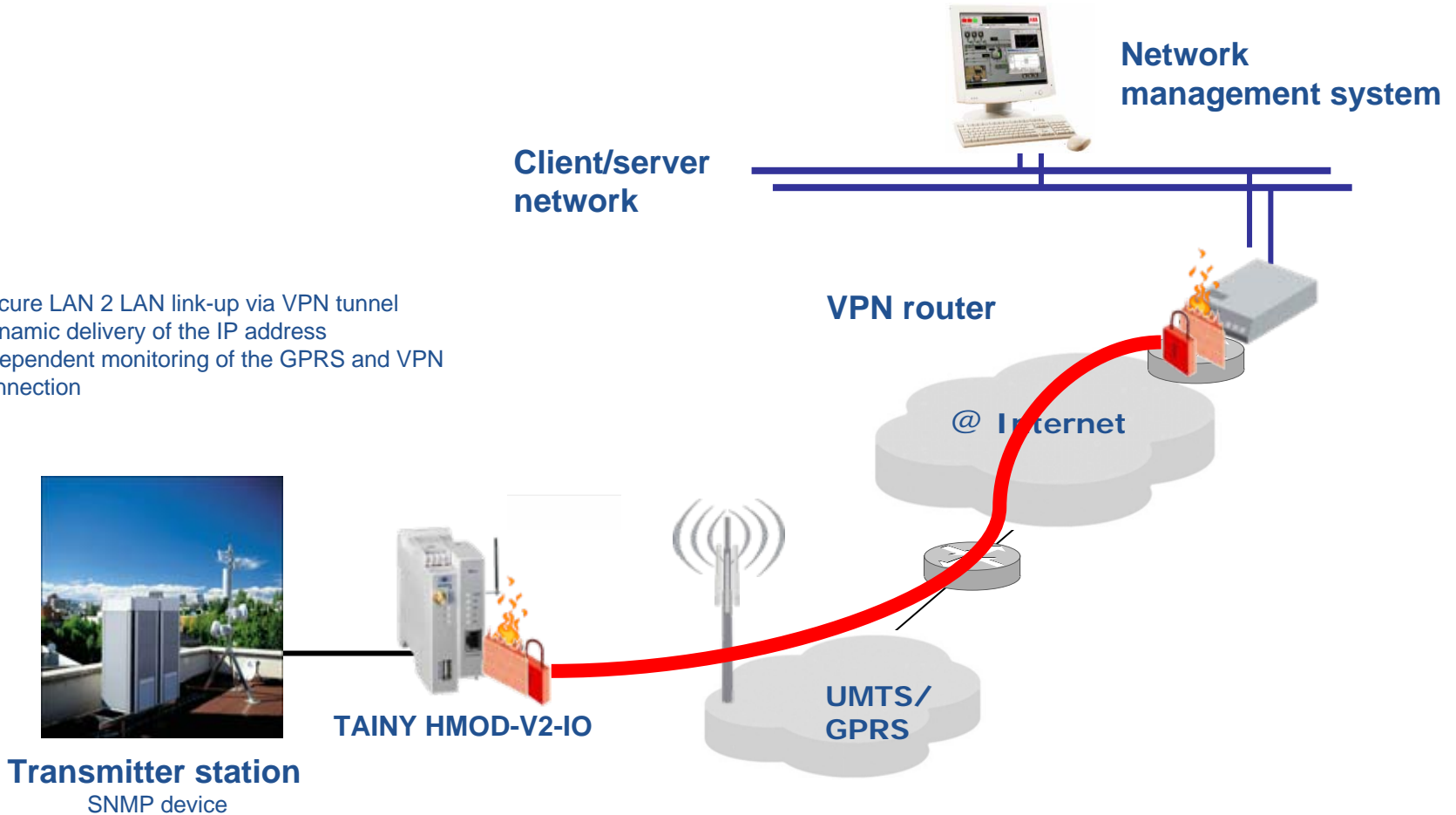

## Remote management – Wireless transmitter stations

- Advantages and benefits for the customer:
  - Reduction of installation costs
  - Reduction of maintenance and operating costs
  - Increase of availability
  - Integration into existing management environment
  - Open system for expansions

## Traffic management system

- Customer requirement:
  - Installation of a controllable traffic management system
- Previously:
  - Extensive use of ground in cities (lines)
  - Installation of leased lines sometimes very complicated and expensive
  - High costs for leased lines
- Requirement:
  - Integration of 6 controllable, guiding units with
    - 17 regular signs and
    - 49 multiple-faced signs



## Traffic management system

- Customer's decision:
  - Connection of the variable message signs via wireless network

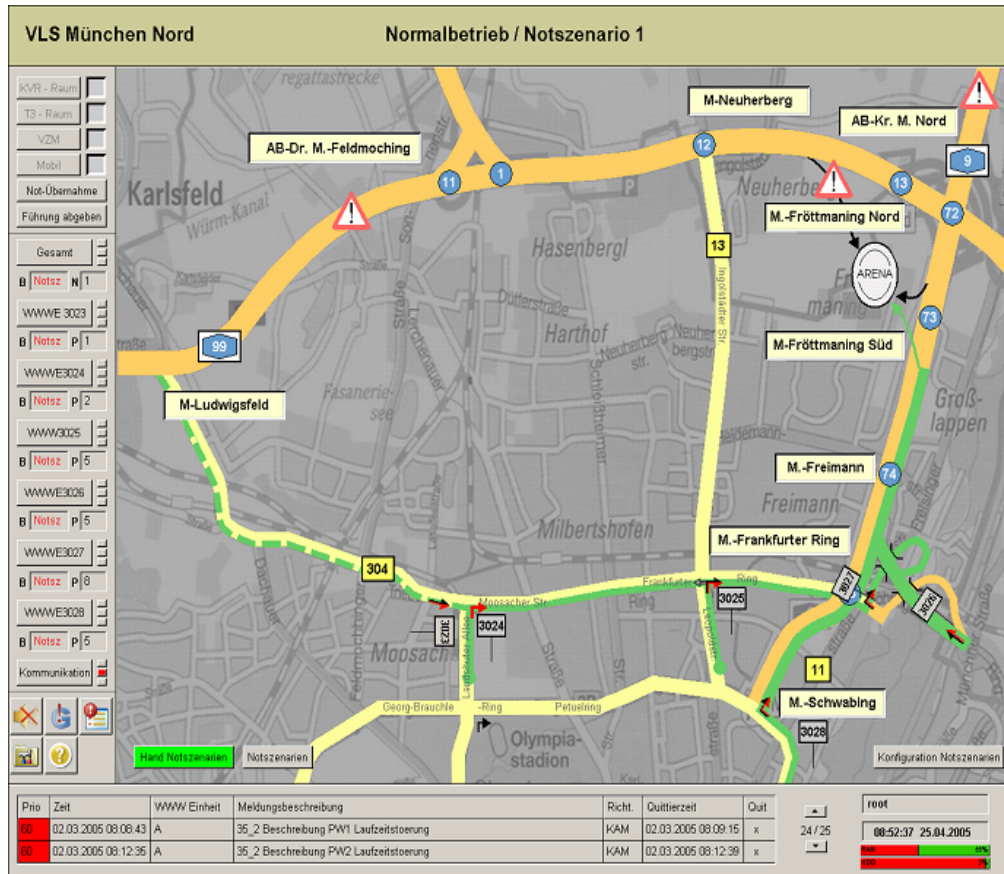

## Traffic management system

- Advantages and benefits for the customer:
  - No need for additional lines
  - Satisfies highest security requirements, thanks to VPN tunnel
  - Inexpensive billing by volume, not by connection time
  - Data transmission always available: almost a leased line
  - Quasi real-time transmission, making immediate reaction possible
  - Cost savings compared to cost of leased lines



# Good reasons to choose the TAINY HMOD-V2-IO

## TAINY HMOD-V2-IO: End-to-end IP connection via wireless network

**Wireless router** for industrial Ethernet network

- **High bandwidth** to transmit **large data volumes** (e.g.: video, images) thanks to **HSDPA router**
- **IPSec-secured, bi-directional** data transmission between the networks
- **Protection** of the decentralized **application** by dynamic **firewall**
- **Proven, cost-efficient connection** for dynamic IP wireless-network environment
- **Intelligent** connection monitoring provides for high availability and stable connections

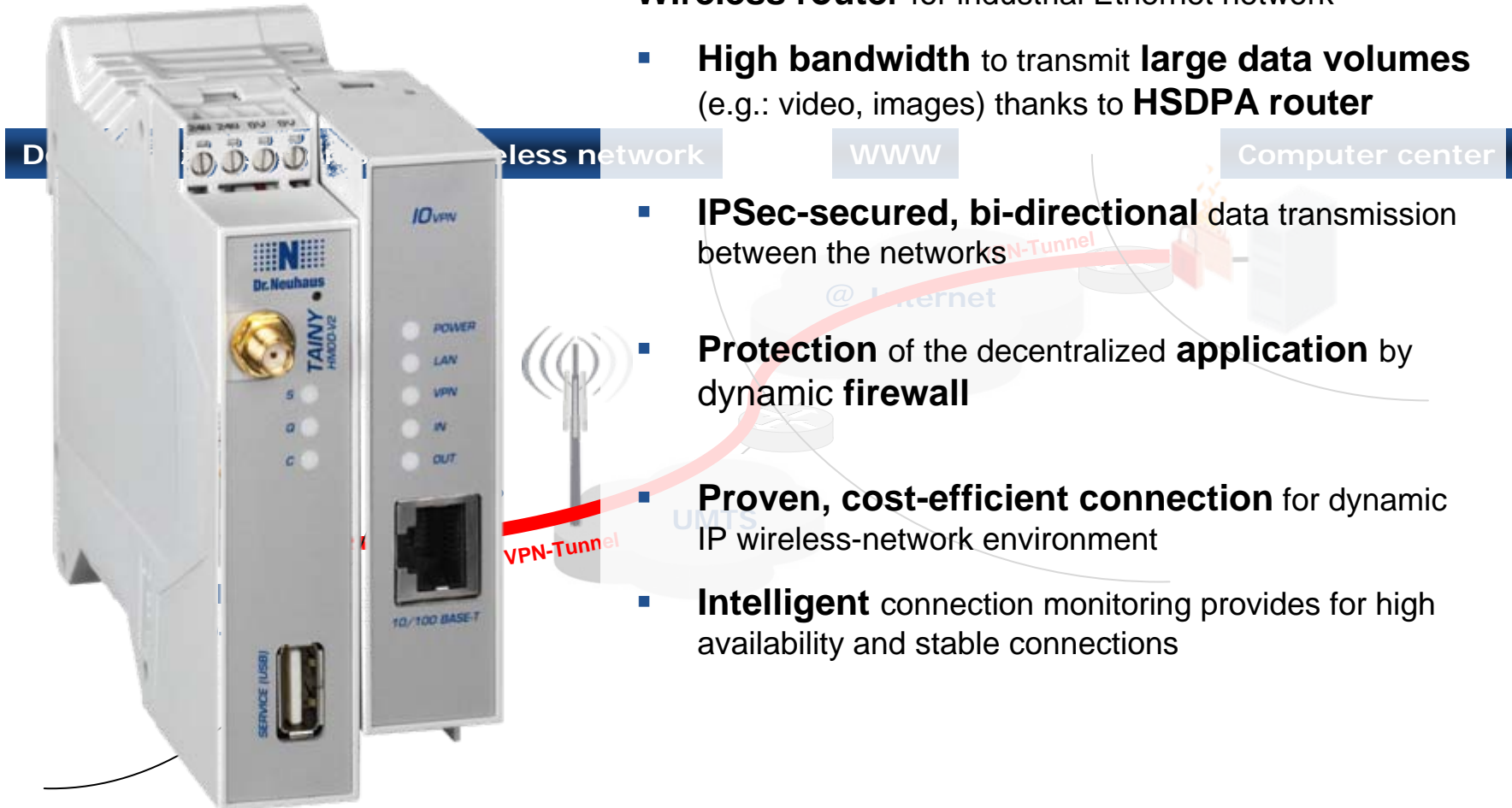

## TAINY HMOD-V2-IO: End-to-end IP connection via wireless network

**Wireless router** for industrial Ethernet network

- **Easy, clear-cut** configuration; by remote or on location

- **UTA (Update over The Air)**-enabled

- **Ethernet** application interface

- Designed to satisfy **industrial** requirements

- **SMS signaling / signaling contacts**



## Summary

- Dr. Neuhaus products are based on open standards and proven “**state-of-the-art**” **technologies**
  - TCPIP, IPsec
  - 3DES, AES, DES
  - Ethernet, HSDPA, UMTS, GPRS, ...
- Clear requirement:
  - Once installed – **Never be out in the field again!**
- Takes into account the requirements of the users
  - through the use of an **open, flexible platform**
  - by focusing on **reliability**
  - by providing **interactive** solutions
- **The technology** follows the **application**

 Please ask any questions you may have !

## Contact:



Internet: [www.neuhaus.de](http://www.neuhaus.de)

Sales: [sales@neuhaus.de](mailto:sales@neuhaus.de)  
+49 (40) 55304 – 203

Support: [support@neuhaus.de](mailto:support@neuhaus.de)  
+49 (40) 55304 – 337



## Appendix: Comparison of wireless communication

	Connection	Technology	Transfer rates (theoretical)		Signal run times	Always on
			Download	Upload		
 <b>GSM</b> 850/900 MHz (2W) 1800/1900 MHz (1W)	Circuit switched	CSD	9,6...14,4 kBit/s	kBit/s		No
	Circuit switched	HSCSD	38,4...57,6 kBit/s	kBit/s		No
	Package oriented	GPRS	62,4 kBit/s	31,2 kBit/s	800-1200ms	Yes
	Package oriented	EDGE	236,8 kBit/s	118,4 kBit/s	300-500ms	Yes
 <b>UMTS</b> 850/1900/2100 MHz (0,25W)	Package oriented	UMTS	384 kBit/s	128 kBit/s	200-300ms	Yes
	Package oriented	HSDPA	max. 7,2 MBit/s	384 kBit/s	100-200ms	Yes
	Package oriented	HSUPA	max. 7,2 MBit/s	max 3,6 MBit/s	100-200ms	Yes

- The actual values of mobile service providers may differ from these values.

## Appendix: Please note !!

- Safety-related applications
  - Emergency systems with 100% availability  
(0.1 % failure rate per year translates as approx. 9 hours)
  - 99.7 % availability reached with redundant wireless communications solution (Kayser Threde solution)
- Protocol requirements for communication
  - Time-critical protocols  
Network runtime behavior (e.g. GPRS approx. 800ms; see Appendix: A comparison of wireless communication)
- Never operate GPRS/EDGE/UMTS without data pricing rate
  - Pulsing is otherwise very high (e.g. 100 kBytes per login)
  - Costs per MB otherwise very high (e.g. € 7.74/MB)  
(For tests or long-term testing, amazing data volumes can be run up very quickly by high pulsing alone)
- Pulsing / billing units
  - Choose 1 kByte for low data volumes (1-10 MBytes) if possible
  - Choose  $\leq 10$  kBytes for medium data volumes (10...100 MBytes) if possible
- Choose a larger volume option in the introductory or test phase