

User Manual

GSM/GPRS Network Termination

SAGEM RT3000



Sagem Communication
Groupe SAFRAN

© by SAGEM COMMUNICATION, 2007

All trade marks and product names are trade marks, registered trade marks or product names of the respective title holders.

The contents of this manual and technical specifications can be changed without notice.

The description of specifications in this manual does not constitute a contract.

Doc. no. 8115AD002 Rev. 1.9

Safety Notes



General: Please read this manual carefully before using the device. The device is for indoor use only. Keep the device out of the reach of children, especially infants. Do not expose the device to moisture, splashes, drips or spray. To avoid the risk of demagnetisation please do not store diskettes, credit cards or similar objects in the vicinity of the device.

Purpose: The sole purpose of the device is to connect telephones, fax machines and modems (or PCs) to the GSM radio networks. Use of this device for any other purpose is prohibited and can be dangerous.

In some countries the use of a GSM-Gateway to access an outside line may constitute a breach of contract.

Installation: For security reasons, the telephone cables must remain exclusively inside the house and must not go outside the house. Never remove a plug from its socket by pulling on the lead and do not lay cables over sharp edges or corners. Do not switch on the device if the lead, another cable or the device itself is damaged. Before connecting or disconnecting other cables please unplug the mains power for all the involved equipment. Never use the device in areas where radio transmission is prohibited.

Health: The device contains a radio transmitter which may affect the operation of medical electronic devices such as hearing aids or heart pacemakers. Your doctor and the manufacturer of such devices can provide you with further advice.

Caution! The distance from all persons to the RT3000 antenna must be at least 20 cm.

SIM card: The device must be opened before being put into operation to insert the SIM card. Before opening the device, always make sure that the cables have been disconnected and the power supply has been directly disconnected at the RT3000, since otherwise dangerous voltages may be present in the device. After the installation remount the cover and fasten it with the supplied screw.

Power supply: Only use the manufacturer's original power supply units. Connect the device's power supply unit only via protective conductor sockets and take care that it is always easily accessible. The voltage specified on the rating plate of the power supply unit must match that of your mains supply. Disconnect the mains plugs of all devices during thunderstorms. In the event of malfunctions disconnect all other cables.

Rechargeable Battery: The battery only serves for short-term bridging of power failures. In case of changing the rechargeable battery installed in the device please take notice of the following:

The device must be opened for the installation of the new rechargeable battery. Opening the equipment during operation may be dangerous. Therefore, make sure to unplug all the connectors before opening. After the installation of the battery, close the cover again and secure both parts with the delivered screw.

Caution! Danger of explosion during inappropriate replacement of the battery!

The battery must not be short-circuited. If the device is removed from service or during works on it, all connections of the battery are to be disconnected.



When replacing the battery, do not dispose of it in the household refuse, but dispose of it properly, in accordance with the local facilities and regulations.

Content

1	Introduction	7
2	The LEDs on the device	8
2.1	GSM Signal Quality Indication	8
3	Putting the device into operation	9
3.1	Survey	9
3.2	Inserting the SIM Card	9
3.3	Connecting the telecomms equipment	10
3.4	Enter the PIN number	11
3.5	Autopin option	12
3.6	Enter the PUK number	13
3.7	Wall-mounting	13
4	Operation: Making and answering telephone calls	14
4.1	Call a remote party	14
4.2	Emergency call	15
4.3	Hotline service	15
4.4	To answer an incoming phone call	16
4.5	Option: Having two calls at the same time	17
5	Operation: Send and receive fax with a facsimile device	19
5.1	To receive a Test Fax	20
5.2	In case of a FAX Warning	20
6	Operation: Analogue Modem connections	21
7	Operation: Send and receive fixed network SMS	22
7.1	In case of error	23
8	Configuration	24
8.1	Access code for DTMF configuration	24
8.1.1	Changing the DTMF access code	24
8.2	Ports for incoming calls; volume of voice signal	25
8.2.1	To select ports for incoming telephone calls	25
8.2.2	Volume of voice signals in telephone calls	25
8.3	Configuration of network services	27
8.3.1	Call forwarding unconditional (CFU)	27
8.3.2	Call forwarding if busy (CFB)	28
8.3.3	Call forwarding if no answer (CFNRy)	29
8.3.4	Call forwarding if not accessible (CFNA)	30
8.3.5	Call barring all of outgoing (To block all outgoing calls)	31
8.3.6	Call barring incoming (To reject all incoming calls)	31
8.3.7	Call Barring international outgoing (To block all outgoing international calls):	32
8.3.8	Change Password for Call Barring	33
8.3.9	Call waiting	33
8.3.10	Check status for call forwarding, call barring and call waiting	33
8.4	FAX-Configuration	34

8.4.1	Fax Report on success	34
8.4.2	Select Port for Fax Calls	34
8.4.3	Disable Modem/Phone on Fax/Modem/Phone port	35
8.5	Data Call Configuration	35
8.5.1	Select Port for Data Calls.....	35
8.6	SMS Configuration.....	36
8.6.1	Select port to receive SMS	36
8.6.2	Configuration for fixed network SMS protocol 1	36
8.6.3	Configuration for fixed network SMS protocol 2	37
8.6.4	Enable/Disable error report.....	38
8.7	Delete undelivered SMS	38
8.8	Additional Configuration.....	39
8.8.1	Enable/Disable CLIR (Calling Line Identification Restriction).....	39
8.8.2	Enable/Disable CLIP (Calling Line Identification Presentation).....	40
8.8.3	Dialling Timeout	40
8.8.4	Flash signal detection (used to manage two calls simultaneously).....	41
8.8.5	Enable / Disable SMS Configuration.....	41
9	Installing the RT3000 modem driver on a Windows-PC	42
10	Operation: Internet via GPRS with a PC	53
10.1	Installing the Windows dial-up network connection	53
10.2	To connect and disconnect to/from the GPRS / Internet.....	59
11	Operation: Using a PC to send and receive fax	60
12	Operation: Using a PC to transmit and receive data.....	61
13	Operation: Using a PC to send and receive SMS.....	62
14	For experienced Users: AT commands.....	63
14.1	AT Command Interface.....	63
14.2	AT commands supported by the SAGEM RT3000	64
14.2.1	AT Command Interface (SMS).....	70
14.2.2	AT Command Interface (SIM APPLICATION TOOLKIT)	74
15	Configuration methods	79
15.1	Configuration by DTMF	81
15.2	Remote configuration by SMS	83
15.3	Configuration by FTP (Local and Remote).....	84
16	Parameters in the file para.ini: advanced configuration.....	86
16.1	Settings for configuration access via DTMF.....	86
16.2	Settings for the configuration access via SMS and FTP	87
16.3	Power-missing SMS.....	88
16.4	Select Port for Incoming SMS.....	88
16.5	Select Baudrate for Debug-RS232.....	89
16.6	Pre-Selection	89
16.7	Prefix for International calls.....	90
16.8	Prefix for Analogue Data and Fax calls.....	90
16.9	Local accepted emergency number	90
16.10	Port Allocation.....	91

16.11	Analogue Fax Configuration	92
16.12	Billing Tone configuration	93
16.13	CLIP function configuration.....	95
16.14	Configuration of the Flash signal	96
16.15	RING frequency	97
16.16	Dialling configuration	97
16.17	Call Wait Tone On/Off	98
16.18	Local Ringback tone on/off	98
16.19	Voice signal volume on Telephone and Fax/Modem/Phone port.....	99
16.20	Telephone and Fax/Modem/Phone port impedance	99
16.21	GPRS Configuration	100
16.22	CLIR on/off	101
16.23	PIN number	101
16.24	AT command parameter	101
16.25	Polarity reversal (Spain)	102
16.26	Hang-up delay	102
16.27	MNP Flow Control.....	103
16.28	Maximum local modem speed	103
16.29	Minimum local modem speed	103
16.30	GSM speed.....	104
16.31	Early connect of local Modem.....	104
16.32	Data numbers	104
16.33	GSM baudrate depending on dialled number (number).....	105
16.34	GSM baudrate depending on dialled number (baudrate).....	105
16.35	Fixed Network SMS	106
16.36	Frequency band selection GSM 900, DCS 1800, PCS 1900	107
16.37	Identification	108
16.38	Hotline Service	108
16.39	Sample File.....	109
17	Configuration of Tones	115
17.1	How to program a new timing	117
17.2	Example-File:.....	118
18	Logfile.....	120
19	Update the firmware	121
20	Connection sockets.....	122
21	Technical data.....	123

1 Introduction

Purpose of the device

The SAGEM RT3000 is a GSM/GPRS Network Termination, a kind of wireless telephone socket. The following devices can be connected to the SAGEM RT3000:

- one or more analogue telephone devices to make telephone calls
- other analogue telecomms equipment: e. g. fax machine or fax modem to send and receive facsimile messages; telephone devices are possible, too.

You can also connect a PC to send or receive data or facsimile messages, further to surf in the internet or send and receive E-mails via GPRS.

The GSM network is used to communicate with the remote party. The connected devices will function almost as though they were connected to the fixed telephone network. There are only some small differences.

To learn about them and to put the device into operation please study this guide.

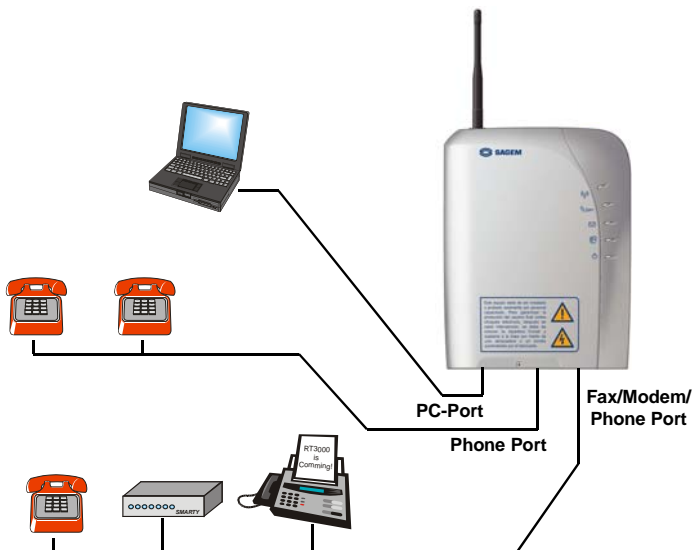





PC based functions

Also all functions related to a PC (GPRS, PC-Modem, PC-FAX, SMS) are described in this user manual.

2 The LEDs on the device

The LEDs inform you about the operation status.

	SLOW Flash	Search Net
	ON	High Signal Quality
	RAPID Flash	PIN SIM missing
	Cadence Flash	Enter PUK Code
	SLOW Flash	Search Net or Low Signal Quality
	On	Medium or High Signal Quality
	Off	No Signal
	RAPID Flash	FAX Warning, please check the fax machine connected to the SAGEM RT3000
	SLOW Flash	SMS Received
	ON	Offhook on Phone, Fax/Modem/Phone or PC port
	RAPID Flash	FAX Warning, please check the fax machine connected to the SAGEM RT3000
	SLOW Flash	Call Barring / Call Forward enabled
	Off	No Power
	Red on	Powered from internal battery
	Green on	Powered from mains

2.1 GSM Signal Quality Indication

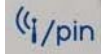
		
Search Net	SLOW Flash	SLOW Flash
No Signal	OFF	OFF
Low Signal Quality	OFF	SLOW Flash
Medium Signal Quality	OFF	ON
High Signal Quality	ON	ON

3 Putting the device into operation

3.1 Survey

Do the following steps:

	page
1. Insert the SIM card	9
2. Connect the power supply and at least one telephone. You may connect your other devices, too.	9
3. Enter the PIN number so that the device can communicate via the GSM network.	11
4. Option: If you have connected a Personal Computer to the SAGEM RT3000, install the corresponding driver on the computer.	20

Now the SAGEM RT3000 is ready to be used.

4. Configure the device according to your needs	24
---	----

3.2 Inserting the SIM Card

Precondition

- ⊘ The SAGEM RT3000 must not be connected to any device. Even the power supply must be disconnected from the SAGEM RT3000.



- ⊘ **Please do not touch the electronic components inside the SAGEM RT3000.**

The steps...

Perform the following steps:

1. Remove the antenna.
2. Remove the lock screw and the bottom part of the housing cover.
3. Open the SIM card holder.
4. Insert the SIM card.
5. Close the SIM card holder.
6. Close and lock the housing with the screw.

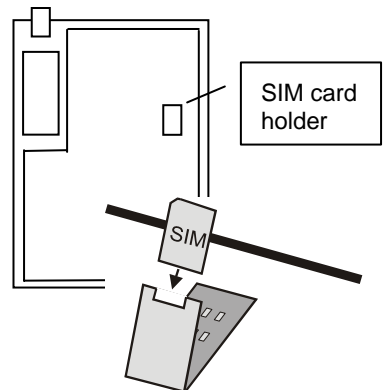

When the SIM card is inserted and the SIM card holder is closed, the gold-metal plated areas of the SIM card must be at the bottom.

3.3 Connecting the telecomms equipment

To put the device into operation you have to connect at least

- the power supply so that the device gets power
- one telephone device, so that you can enter the PIN number.

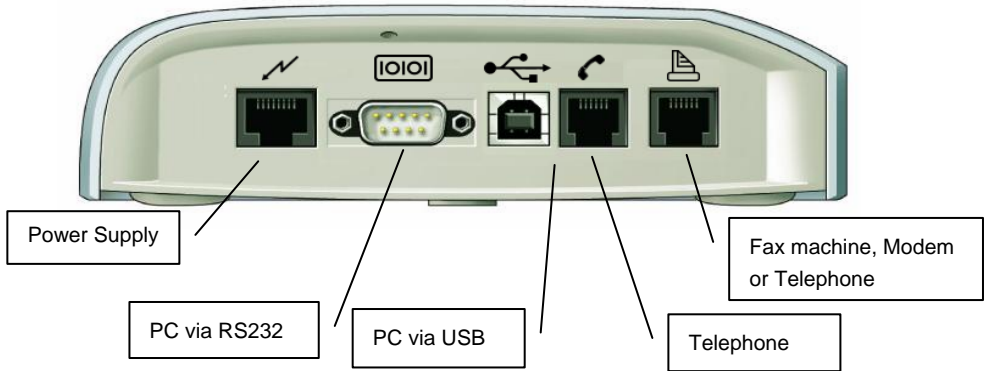

Power Supply



Connect the Power Supply adapter here. Use only the Power supply adapter supplied with the RT3000. Plug-in the Power supply adapter into the mains socket.

RS232 (optional)

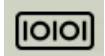

Connect this interface with the COM port (serial RS-232 interface) of your computer, if you want to have access to the internet or if you want to use your computer for fax and data communication. If you connect a device to the USB port, the RS-232-Port will be deactivated.

Default settings:

Transmission speed	57,600 bps
Data bits	8
Parity	N (none)
Stop bits	1

USB (optional)

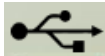

If you want to connect your computer via its USB interface instead of its COM port to the SAGEM RT3000, please first install the drivers and then plug in the USB cable.

Telephone



You can connect here analogue telephones.

Fax/Modem/Phone



You can connect here analogue telecomm equipment, e.g. analogue fax machine (or a combi fax), analogue modem or analogue telephones

- The total number of telephones and telecomm equipment connected to the RT3000 may not exceed a REN (=Ringer Equivalent Number) of 5. A standard analogue telephone has the REN of 1.
- All devices connected to one port of the SAGEM RT3000 are switched in parallel. That means they react in the same way: For example when there are 2 telephone sets connected to the **Telephone** port and a call comes in, both telephone sets will ring and you can answer the call using any of them.
- If you connect a Personal Computer, you have to install the modem driver of the SAGEM RT3000 on the computer.
- For security reasons, the telephone cables must remain exclusively inside the house, not go outside the house. The maximum distance between the RT3000 and conventional telephone sets or fax machines is 300 meters with 0,4 mm cable assuming a total loop impedance including telephone equal to 500 Ω maximum. The maximum distance between the RT3000 and PC should not exceed 3 meters.
- If the power supply adapter is disconnected, the SAGEM RT3000 is shut down. Even if the RT3000 is powered by the internal battery (in case of a mains failure), the power supply adapter shall be connected to the SAGEM RT3000.

3.4 Enter the PIN number

Before you can use the RT3000, enter the PIN (Personal Identification Number). You will receive the PIN number with the SIM card from your network provider.

- If you have received a RT3000 with Autopin function read chapter 3.5 before going on.

To enter the PIN use a telephone set connected to the **Telephone** port or the **Fax/Modem/Phone** port of the RT3000. Use the telephone to enter the PIN (by sending DTMF codes to the RT3000) just as you would dial a number:

When you pick up the handset (go off hook), you will hear a recurrent short beep tone, that prompts for the PIN. Enter the PIN as shown below, then hang up (place the handset on hook).

To enter the PIN:



It means:

P P P P Please enter your PIN number here .
Allowed PIN numbers are 0000 to 99999.



means: listen to the confirmation tone:
a high pitched bip signals: OK
a low frequency beep-beep signals: Wrong PIN

You may have to wait 3 seconds before hearing the confirmation tone.



means lift up the handset



means hook on the handset

If you have entered a wrong PIN, the  LED will flash rapidly. You have one last try to enter the right PIN. This last try is indicated by a special beep tone. If you have entered two times the wrong PIN, the SIM card is locked and you need to unlock it by entering the PUK (see chapter 3.6).

3.5 Autopin option

Autopin is a special function to prevent against the use of the SAGEM RT3000's SIM card in an other terminal.

Please insert the SIM card as described on page 9 and turn-on the SAGEM RT3000. Enter the PIN of the SIM card. The SAGEM RT3000 will automatically change the PIN number by a secret value.

Be careful, you can enter only once a correct PIN! After the SAGEM RT3000 turned into normal operation status use these sequences for clearing the original PIN code from registers.

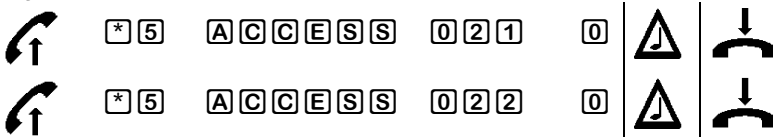

If the SAGEM RT3000 restarts again with this same SIM card, you will no more have to enter the PIN: the SAGEM RT3000 will use its secret value.



3.6 Enter the PUK number

If you have entered the three times in sequence a wrong PIN, the  LED will flash with a significant cadence. In this case you have to enter the PUK (Personal Unblocking Key) which you should have received from your network provider with your SIM card. This will unblock the SIM card.

To enter the PIN:



It means:

-  Please enter your PUK here.
-  Please enter a new PIN here.
Allowed PIN numbers are 0000 to 99999.

3.7 Wall-mounting



-  **Please operate the SAGEM RT3000 only in upright position with the antenna pointing upwards. This will ensure best signal quality.**

The RT3000 is intended to be mounted on the wall. This will ensure best transmission quality. You can fix it to the wall with screws.

To mount the device on the wall, first disconnect all the cables. In particular make sure that the power cable is not connected.

We suggest that you check the reception before finally fixing the mounting.

4 Operation: Making and answering telephone calls

- Though you can connect many of devices to the SAGEM RT3000 only one call - incoming or outgoing - is possible at a time, because there is only a single "wireless" line for communication. Other devices will get a busy tone.
- You can connect analogue telephone sets either to the **Telephone** port or to the **Fax/Modem/Phone** port of the SAGEM RT3000. Up to five devices can be connected to each port but the total number of devices connected to the RT3000 shall not exceed five. You can make or answer telephone calls with each telephone set.
- Please note that the maximum REN (=Ringer Equivalent Number) at the RT3000 may not exceed 5. A standard analogue telephone has the REN of 1. All devices connected to one port of the SAGEM RT3000 are switched in parallel and react in the same way. That means they react in the same way: For example when there are 2 telephone sets connected to the **Telephone** port and a call comes in, both telephone sets will ring and you can answer the call using any of them.
- DTMF dialling as well as pulse (decadic) dialling are supported.
- Depending on the network, when a number is dialled to make a call, you may need to enter the local area code, even if it is a local call.

4.1 Call a remote party

To make a call...

Lift up the telephone handset and enter the phone number of the remote party.

You will hear:

- the common call progress tones, like the dialling tone (before entering the phone number),
- the ringing tone (during the time the remote party gets the RING signal),
- or a busy signal (if the remote party is busy or the connection cannot be established).
- If an active connection (GPRS, GSM data, Fax or another voice connection) has already been established using the SAGEM RT3000 and you try to make a call, you will hear a busy signal since another device is currently using the only "wireless" line.

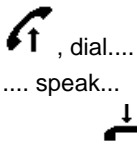

To terminate the call...

Hang-up the handset.

4.2 Emergency call

You may place an Emergency calls e.g. to your local police or fire department without a SIM card inside the RT3000. Just dial the number.

4.3 Hotline service

The SAGEM RT3000 features a hotline service to dial automatically a registered telephone number just by lifting the telephone handset. This function is very comfortable if you like to call often the same phone number.

To make a hotline call...

Lift up the telephone handset. The SAGEM RT3000 dials automatically the registered phone number. You will hear:

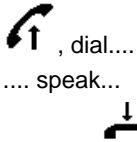

- the dialling tone (before the SAGEM RT3000 starts to dial). While the dialling tone is active, you can dial any other number,
- silence for a short moment until the hotline number is dialled,
- the ringing tone (during the time the remote party gets the RING signal),
- or a busy signal (if the remote party is busy or the connection cannot be established).



To terminate the call...

Hang-up the handset.

To call another telephone number than the registered one, the SAGEM RT3000 waits a certain time ("Time before dialling") before it starts to dial the hotline number. During this time, you can dial any number. Entering any digit, the hotline service is deactivated until you hang-up again.

	Description:
 * 5 3 * <Hotline number> * <Time before dialling> #	Registers the hotline phone number and activates the hotline service. Time before dialling : 5...60 (5 = 5 sec, 60 = 60 sec)
 * 5 3 #	Activates the hotline service (only if a hotline number is registered)
 # 5 3 #	Deactivates the hotline service



Check the status for hotline service

When you check the status for the hotline service, the status will be indicated by signal tones from the telephone handset:

	Description:
___ Bip ___ Bip	Status on / DTMF code correct
___ Beep _ Beep ___ Bip	Status off / DTMF code correct
___ Beep_ Beep	DTMF code not correct

4.4 To answer an incoming phone call

When the telephone is ringing...

An incoming phone call is indicated by a RING signal of the telephones connected to the **Telephone** port or to the **Fax/Modem/Phone** port of the SAGEM RT3000.

Lift up the handset of the telephone set and speak.



- By default you cannot have two calls at the same time. So if a call comes in during an active connection (GSM data (CSD), Fax or voice connection), this incoming call will not be signalled to you. And the calling party will get a busy signal, because the only "wireless" line is used by an other device.
- During a GPRS-connection an incoming call will not be signalled to you if data is exchanged. The calling party will get a busy signal. In case of no data traffic, e.g. you are surfing in the Internet and the download of the requested page has been completed, the incoming call will be signalled to you.
- In some cases you can continue speaking even when you have hung up and then lifted up the handset within 1 minute. (See Parameter *hang-up delay* in the section *Advanced Configuration* in this User manual.)

4.5 Option: Having two calls at the same time

- ☎ During making a telephone call it is possible to receive a second call or to establish a second call, if this service is supported by:
- the network
 - and your subscription
 - and if configured (see Call waiting, page 33).

By default this function is not activated.

To establish a second call...

To put the call already established in Call Hold state press the following keys in sequence:



Then you can make another call.

To answer a second call during a call...

When a second call comes in during a call, you hear a Call Waiting Advising Tone to inform you about the incoming second call. Then you can:

- ⇒ Put the first call in Call Hold state and switch to the second call by pressing the following keys in sequence:



You can toggle between the two calls by pressing the keys in sequence.

OR

- ⇒ Hook on the handset to finish the first call. In this case the call in Call Waiting state is not rejected. It is indicated like any normal incoming call by ringing.

OR

- ⇒ Do nothing, continue with the first call. After some time - the duration depends on the network - the second call is transferred to the voice mail box (Call Forwarding on No Reply - CFNRy), if this feature is enabled. Otherwise the calling party will hang-up, because his call is not answered.
-

To manage two calls (3-party conference calls)

In a situation with two established calls with one in Call Hold state (see above) you can:

- ⇒ Switch from one call to the other by pressing the following keys in sequence: **R** **2**
- The active call will change to Call Hold state and vice versa.

-
- ⇒
- Transform the two calls in a 3 parties call (multi party call):
 - Press the following keys in sequence: **R** **3**
-

- ☞ You can configure the telephone functions according your needs. See *Configuration* page 24.

5 Operation: Send and receive fax with a facsimile device

- You can send and receive G3 fax with a standard analogue facsimile device which is connected to the **Fax/Modem/Phone** port of the SAGEM RT3000. Please install and operate the facsimile device in accordance to its user manual.
- If you want to send or receive a fax with a Personal Computer, which is connected to the RS-232 port or USB port, you have to configure the SAGEM RT3000 accordingly.

Please note:

The SAGEM RT3000 is equipped with very advanced fax technologies, ensuring best results in fax transmission via GSM. Nevertheless, due to the nature of GSM fax, correct fax communications cannot be guaranteed at all places and at all the time.



The “wireless telephone line” provided by the SAGEM RT3000 has special characteristics you should know:

- Please configure the connected facsimile device so that an incoming call is answered after the first, second or the third RING signal - not later. Otherwise you may have problems to receive a fax.
- Please check that no call forwarding is activated for the fax service (see chapter 8.3). Otherwise a fax, which is sent to the SAGEM RT3000 will not be received by the SAGEM RT3000 but by a fax mail box.
- In case of a faulty fax transmission to a remote party, it might happen nevertheless that your facsimile will report that the transmission was successful. So in the case of faulty fax transmission the SAGEM RT3000 will send an error message report to your facsimile device to correct this problem. Only if you are not receiving such an error message report, you can be sure, that the fax was transmitted successfully. You can also activate a mode, that you will receive a transmission report (transmission successful / not successful) after each fax transmission to a remote party.
- While receiving a fax from a remote party, it might happen that the sending party already receives the confirmation that the fax has been transmitted to you successfully even though you did not yet receive it completely for any reason (i.e. out of paper). In such a case the undelivered part of the fax will be stored inside the SAGEM RT3000. It will indicate this by both FAX Warning LEDs rapidly flashing (see LED description on page 8). The SAGEM RT3000 will do some retries to deliver the rest of the received facsimile. If it is not successful, it continues to indicate this by both FAX Warning LEDs rapidly flashing. You can request the delivery of the partly stored fax by entering a DTMF command by a connected telephone set (see below
- *In case of a FAX Warning, page 20).*



5.1 To receive a Test Fax

To check if your facsimile device can receive a fax from the SAGEM RT3000 correctly, you can make a test:



    A test fax of 1 page will be transmitted from the SAGEM RT3000 to your facsimile device.



 means: wait for the confirmation tone (up to 3 sec):
a high pitched bip signals: OK
a low frequency beep-beep signals: Wrong entry.

5.2 In case of a FAX Warning

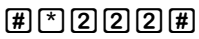
If both FAX Warning LEDs are rapidly flashing, the SAGEM RT3000 is indicating that it could not transfer a received fax to the connected facsimile device completely (see above). The part that is not transferred is stored in the SAGEM RT3000. Please check your facsimile device. Be sure that it is in correct operation mode. Then give the command to the SAGEM RT3000 to transfer the stored fax to your facsimile device. Use a telephone connected to the **Telephone** port or to the **Fax/Modem/Phone** port to give the following command:

Description:

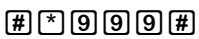
    After you have entered the code, the SAGEM RT3000 will start to send the saved fax part to your facsimile device.

    This command will delete the partly saved fax and will reset the FAX Warning.

 means: wait for the confirmation tone (up to 3 sec):
a high pitched bip signals: OK
a low frequency beep-beep signals: Wrong entry.

 You can configure the fax function according your needs. See page 34.

6 Operation: Analogue Modem connections

- With an analogue modem connected to the **Fax/Modem/Phone** port of the SAGEM RT3000 you can send and receive data to/from a remote modem being connected to an analogue telephone line. Please install and operate the modem in accordance to its user manual and the manual of the software you run on the computer connected to the modem.
The called party can be a GSM modem or a fixed network modem.
- If the called party's modem is connected to the fixed network, it should support 9600 bps (V.32) / V.42 for the connection into the fixed network. This is necessary for the communication to the GSM network.
- The SAGEM RT3000 supports
 - modem connections up to 9600 bps
 - modem connections according to the ITU-Standards V.21, V.22, V.22bis and V.32.Your modem should support MNP2 to ensure that no data are lost due to flow control problems.
- For data communication you can also connect your PC to the SAGEM RT3000 directly using this device as GSM modem (see details page 42).
- You can configure the function according your needs. See *Data Call Configuration*, page 35.

7 Operation: Send and receive fixed network SMS

If you have connected a telecomm equipment to the SAGEM RT3000 that is capable of sending and receiving fixed network SMS (see note), you can use the fixed network SMS (SMS = Short Message Service).

The RT3000 is a SMS centre for fixed network SMS. It can receive fixed network SMS from a connected telecomms equipment and forward it through the GSM network to the final recipient. It can also receive SMS from the GSM network and forward it to a connected fixed network SMS telecomms equipment.

To receive fixed network SMS the device you use must be connected to the port on which incoming SMS are delivered (Default: PC-port).

The function requires some configuration:

Do the following steps:

- | | page |
|---|-------------|
| 1. Select the port of the RT3000 to which incoming SMS should be sent. | 36 |
| 2. The RT3000 supports fixed network SMS in accordance to ETSI standard ES 201 912 Protocol 1, Deliver mode 0 and Protocol 2.
Check if your fixed network SMS telephone supports Fixed network SMS in accordance protocol 1 or protocol 2.
You should find the information in the user guide of the telephone.
May be that you have to ask your provider for these number. | |
| 3. Choose the right protocol in accordance to your telecomms equipment.
Configure the SMS centre number for protocol 1 or SMS centre number and Local number for protocol 2. | 36 |

How to enter an SMS, how to send it and how you can receive a SMS is described in the user guide of your telecomms equipment.

7.1 In case of error

Sending a SMS In case of error the RT3000 can send an error report on the telecomms equipment you have used to send the SMS. You can activate or deactivate this function (see page 38).

Receiving a SMS When the SAGEM RT3000 detects an incoming SMS it will give notice to the device that is connected to its configured SMS-port (see *Select port to receive SMS*, page 36), so that this device will ring, receive the SMS and display it.

When the SAGEM RT3000 is not successful to transfer the SMS it will retry to repeat the transmission 2 times.

If the SAGEM RT3000 is still not successful to transfer the SMS after these retrials, the user can invoke a retransmission when his device is ready.

To do this enter the following sequence:

Description:

 *10#



After you have entered the code, the SAGEM RT3000 will restart the transmission.



means: wait for the confirmation tone (up to 3 sec):

a high pitched bip signals: OK

a low frequency beep-beep signals: Wrong entry.

8 Configuration

Your SAGEM RT3000 is a sophisticated device with a wide range of modes of operation. You have to decide which operation modes are appropriate for your needs and then enable them by configuring the SAGEM RT3000.

The configuration process Use a telephone connected to the **Telephone** port or the **Fax/Modem/Phone** port of the RT3000 to enter a special sequence (see below) just as you would dial a number. (The telephone must use tone (= DTMF) dialling.)

The icons in the following descriptions mean:



listen to the confirmation tone:
 a high pitched bip signals: OK
 a low frequency beep-beep signals: Wrong entry.

You may have to wait 3 seconds before hearing the confirmation tone.



lift up the handset.



hook on the handset.

A C C E S S means: access code; by default it is **0 0 0 0 0 0**

8.1 Access code for DTMF configuration

8.1.1 Changing the DTMF access code

The configuration of your SAGEM RT3000 is protected against unauthorised modification by an access code. The access code is part of each DTMF configuration code apart from the DTMF codes to configure call forwarding and call barring.

The access code consists of 6 numeric digits. The default value is **0 0 0 0 0 0**.

* **5** **0 L D A C C** **0 2 3** **N E W A C C** #

It means:

0 L D A C C : old access code









N E W A C C : new access code

8.2 Ports for incoming calls; volume of voice signal

8.2.1 To select ports for incoming telephone calls

By default, the **Telephone** port and the **Fax/Modem/Phone** port will RING when a call comes in.

To change the setting enter the following sequence:







Default access code: 000000	Incoming phone call is signalled on:
 *5 ACCESSS 009 1 #  	Only on Telephone port
 *5 ACCESSS 009 2 #  	Only on Fax/Modem/Phone port
 *5 ACCESSS 009 4 #  	Telephone port and Fax/Modem/Phone port (Default)

8.2.2 Volume of voice signals in telephone calls

You can adjust the volume of the voice signal which is sent to the remote party. You can also adjust the volume of the voice signal which is received from the remote party.









To change the setting enter the following sequence:

Telephone port:

Default access code: 000000	Description:
 *5 ACCESSS 001 VV #  	Volume sent to remote party
 *5 ACCESSS 002 VV #  	Volume of voice signals received from remote party

Fax/Modem/Phone port:



To change the setting enter the following sequence:

Default access code: 000000		Description:
 * 5 A C C E S S 0 0 3 V V #  	Volume sent to remote party	
 * 5 A C C E S S 0 0 4 V V #  	Volume of voice signals received from remote party	
Meaning:	  = 00 ... 20 with 00 = maximum volume with 20 = minimum volume	

Factory setting: 07

Example:

You want to increase the volume of voice signals received from the remote party when you use the **Telephone** port:

Lift up the handset  ,
then enter: * 5 0 0 0 0 0 0 0 0 0 2 0 3 #
and wait for the confirmation tone ,
then hang-up the handset .

8.3 Configuration of network services

Your SAGEM RT3000 is a sophisticated device with a wide range of modes of operation. You have to decide which operation modes are appropriate for your needs and then enable them by configuring the SAGEM RT3000.

The configuration process Use a telephone connected to the **Telephone** port or the **Fax/Modem/Phone** port of the RT3000 to enter a special sequence (see below) just as you would dial a number. (The telephone must use tone (= DTMF) dialling.)

The icons in the following descriptions mean:



listen to the confirmation tone:
a high pitched bip signals: OK
a low frequency beep-beep signals: Wrong entry.

You may have to wait 3 seconds before hearing the confirmation tone.



lift up the handset.



hook on the handset.

A C C E S S means: access code; by default it is **0 0 0 0 0 0**

8.3.1 Call forwarding unconditional (CFU)

If *call forwarding unconditional* is activated incoming calls will be forwarded to the configured telephone number. You can configure this for each type of call (voice, data, fax) independently.

To change the setting enter the following sequence:

	Description:	
* * 2 1 * <Telnumber> #		Activates for all call types
* * 2 1 * <Telnumber> * <call_type> #		Activates for selected call types (see below)
# # 2 1 #		Deactivates call forwarding unconditional
* # 2 1 #		Status Checking (see p. 33)

Meaning:

<Telnumber> = the telephone number, the call will be forwarded to

<call_type> = **1 1** : Incoming **phone calls** will be forwarded.

<call_type> = **1 3** : Incoming **fax calls** will be forwarded.

<call_type> = **2 5** : Incoming **data calls** will be forwarded.













Both prefix commands ***** and *** *** are supported to activate the service.

Both prefix commands **#** and **# #** are supported to deactivate the service.

8.3.2 Call forwarding if busy (CFB)

If *Call forwarding if busy* is activated, incoming calls will be forwarded to the configured telephone number, if the SAGEM RT3000 is just busy in performing a telephone, fax or data call when calls come in. You can configure this for each type of call (voice, data, fax) independently.

To change the setting enter the following sequence:

		Description:
 * * 6 7 * <Telnumber> #	 	Activates for all call types
 * * 6 7 * <Telnumber> * <call_type> #	 	Activates for selected call types (see below)
 # # 6 7 #	 	Deactivates call forwarding if busy
 * # 6 7 #	 	Status Checking (see p. 33)

Meaning:

<Telnumber> = the telephone number, the call will be forwarded to

<call_type> = **1 1** : Incoming **phone calls** will be forwarded.

<call_type> = **1 3** : Incoming **fax calls** will be forwarded.

<call_type> = **2 5** : Incoming **data calls** will be forwarded.



















Both prefix commands ***** and *** *** are supported to activate the service.

Both prefix commands **#** and **# #** are supported to deactivate the service.

8.3.3 Call forwarding if no answer (CFNRy)

If *call forwarding if no answer* is activated, incoming calls will be forwarded to the configured telephone number, if the call is not answered by a connected telecomms equipment. You can configure this for each type of call (voice, data, fax) independently. You can also configure the delay after the call is forwarded.

To change the setting enter the following sequence:

	Description:
 * * 6 1 * <Telnumber> #  	Activates for all call types
 * * 6 1 * <Telnumber> * * <delay_time> #  	Setting the delay after which the call is forwarded for all call types
 * * 6 1 * <Telnumber> * <call_type> #  	Activates for the selected call types (see below)
 * * 6 1 * <Telnumber> * <call_type> * <delay_time> #  	Specifies the target number, the call type and the delay.
 # # 6 1 #  	Deactivates call forwarding if no answer
 * # 6 1 #  	Status Checking (see p. 33)

Meaning:

<Telnumber> = the telephone number, the call will be forwarded to

<delay_time> = the delay, after which the call is forwarded in seconds

<call_type> = 1 1 : Incoming **phone calls** will be forwarded.

<call_type> = 1 3 : Incoming **fax calls** will be forwarded.

<call_type> = 2 5 : Incoming **data calls** will be forwarded.













Both prefix commands * and * * are supported to activate the service.

Both prefix commands # and # # are supported to deactivate the service.

8.3.4 Call forwarding if not accessible (CFNA)

If *call forwarding if not accessible* is activated, incoming calls will be forwarded to the configured telephone number, if your SAGEM RT3000 is not accessible in the GSM network so that the call can not be answered by telephone, fax or data device. You can configure this for each type of call (voice, data, fax) independently. You can also configure the delay after the call is forwarded.

To change the setting enter the following sequence:

	Description:
 * * 6 2 * <Telnumber> #	  Activates for all call types
 * * 6 2 * <Telnumber> * <call_type> #	  Activates for selected call types (see below)
 # # 6 2 #	  Deactivates call forwarding if not accessible
 * # 6 2 #	  Status Checking (see p. 33)

Meaning:

<Telnumber> = the telephone number, the call will be forwarded to

<call_type> = **1 1** : Incoming **phone calls** will be forwarded.

<call_type> = **1 3** : Incoming **fax calls** will be forwarded.



















<call_type> = **2 5** : Incoming **data calls** will be forwarded.

Both prefix commands * and * * are supported to activate the service.

Both prefix commands # and # # are supported to deactivate the service.

8.3.5 Call barring all of outgoing (To block all outgoing calls)

If *call barring all of outgoing* is activated, all outgoing calls will be blocked.
To change the setting enter the following sequence:

		Description:
 * 3 3 * <password> #	 	Activates for all call types
 * 3 3 * <password> * <call_type> #	 	Activates for selected call types (see below)
 # 3 3 * <password> #	 	Deactivates call barring all of outgoing for all call types
 # 3 3 * <password> * <call_type> #	 	Deactivates for selected call types (see below)
 * # 3 3 #	 	Checks the status (see p. 33)
 * # 3 3 * * <call_type> #	 	Checks the status (see p. 33)

Meaning:

<password> = the password to protect this service: any number

<call_type> = 1 1 : Configuration is related to **phone calls** only.

<call_type> = 1 3 : Configuration is related to **fax calls** only.















<call_type> = 2 5 : Configuration is related to **data calls** only.



You may also use the code 3 4 instead of 3 3 to configure this service.

8.3.6 Call barring incoming (To reject all incoming calls)

If *call barring incoming* is activated, all incoming calls will be rejected.
To change the setting enter the following sequence:

		Description:
 * 3 5 * <password> #	 	Activates for all call types
 * 3 5 * <password> * <call_type> #	 	Activates for selected call types (see below)
 # 3 5 * <password> #	 	Deactivates call barring incoming for all call types
 # 3 5 * <password> * <call_type> #	 	Deactivates for selected call types
 * # 3 5 #	 	Checks the status (see p. 33)

 * # 3 5 * * <call_type> #	 	Checks the status (see p. 33)
--	---	-------------------------------

Meaning:

<password> = the password to protects this service: any number

<call_type> = **1 1** : Configuration is related to **phone calls** only.



















<call_type> = **1 3** : Configuration is related to **fax calls** only.

<call_type> = **2 5** : Configuration is related to **data calls** only.

8.3.7 Call Barring international outgoing (To block all outgoing international calls):

If *call barring all international outgoing* is activated, all outgoing calls to destinations abroad will be blocked.

To change the setting enter the following sequence:

		Description:
 * 3 3 1 * <password> #	 	Activates for all call types
 * 3 3 1 * <password> * <call_type> #	 	Activates for selected call types
 # 3 3 1 * <password> #	 	Deactivates this function for all call types
 # 3 3 1 * <password> * <call_type> #	 	Deactivates for selected call types
 * # 3 3 1 #	 	Checks the status (see p. 33)
 * # 3 3 1 * * <call_type> #	 	Checks the status (see p. 33)

Meaning:



<password> = the password to protects this service: any number

<call_type> = **1 1** : Configuration is related to **phone calls** only.

<call_type> = **1 3** : Configuration is related to **fax calls** only.

<call_type> = **2 5** : Configuration is related to **data calls** only.

8.3.8 Change Password for Call Barring

	Description:
 * * 0 3 * <old pw> * <new pw> * <new pw> #  	Change password

Meaning:









<old pw> = recently active password for call barring

<new pw> = new password for call barring: any number

8.3.9 Call waiting

If the *call waiting* function is activated, during active telephone calls an incoming call will be indicated by a signal tone.

To change the setting enter the following sequence:

	Description:
 * 4 3 #  	Function activated
 # 4 3 #  	Function deactivated (Default)
 * # 4 3 #  	Check the status (see p. 33)

8.3.10 Check status for call forwarding, call barring and call waiting







When you check the status for call forwarding, call barring or call waiting, the status will be indicated by signal tones from the telephone handset:

	Description:
___ Bip ___ Bip	Status on / DTMF code correct
___ Beep _ Beep ___ Bip	Status off / DTMF code correct
___ Beep _ Beep	DTMF code not correct or service not provided by the network

8.4 FAX-Configuration

8.4.1 Fax Report on success







To change the setting enter the following sequence:

Default access code: 000000	Description:
 * 5 A C C E S S 0 1 3 0 #  	Only error reports are transmitted to your facsimile device (Default)
 * 5 A C C E S S 0 1 3 1 #  	After each transmission to a remote station a report is sent to your facsimile device reporting whether the transmission was successful or not.

-  In case of a faulty fax transmission to a remote party, it might happen nevertheless that your facsimile will report that the transmission was successful. So in the case of faulty fax transmission the SAGEM RT3000 will send an error message report to your facsimile device to correct this problem. Only if you are not receiving such an error message report, you can be sure, that the fax was transmitted successfully. You can also activate a mode, that you will receive a transmission report (transmission successful / not successful) after each fax transmission to a remote party.







8.4.2 Select Port for Fax Calls

To change the setting enter the following sequence:

Default access code: 000000	Description:
 * 5 A C C E S S 0 1 1 0 2 #  	Receive Fax on Fax/Modem/Phone port (Default)
 * 5 A C C E S S 0 1 1 0 3 #  	Receive Fax with Fax software on the PC connected to the RS-232 or USB port

8.4.3 Disable Modem/Phone on Fax/Modem/Phone port







To change the setting enter the following sequence:

Default access code: 000000		Description:
 * 5 A C C E S S 0 1 2 0 0 #  		The Fax/Modem/Phone port will allow outgoing fax, modem and voice calls (Default)
 * 5 A C C E S S 0 1 2 0 1 #  		The Fax/Modem/Phone port will only allow outgoing fax calls

8.5 Data Call Configuration

8.5.1 Select Port for Data Calls

To change the setting enter the following sequence:









Default access code: 000000		Description:
 * 5 A C C E S S 0 1 0 0 2 #  		Receive data call on the Fax/Modem/Phone port (Default)
 * 5 A C C E S S 0 1 0 0 3 #  		Receive data call on the PC port: RS-232 or USB

8.6 SMS Configuration

8.6.1 Select port to receive SMS

You can enter or read a SMS message either by AT commands through the PC port or by using a telephone, being capable of fixed network SMS. You need to select the port, where the SMS is delivered to. To change the setting enter the following sequence:

Default access code: 000000

	Description:
 *5 ACCCESS 019 01 #  	Receive SMS on the Phone port (fixed network SMS)
 *5 ACCCESS 019 02 #  	Receive SMS on the Fax/Modem/Phone port (fixed network SMS)
 *5 ACCCESS 019 03 #  	Receive SMS on the PC -port (Default)

8.6.2 Configuration for fixed network SMS protocol 1

If your telephone supports fixed network SMS protocol 1, please enter the following sequence:



Default access code: 000000

 *5 ACCCESS 027 1 #  	Select Fixed net SMS protocol 1
---	---------------------------------

Your fixed network SMS telephone needs the telephone number of the SMS centre. Choose any number and configure this number in both, your telephone and the RT3000.

For the configuration of the RT3000 please enter the sequence below:

Default access code: 000000



 *5 ACCCESS 024 <SMS_Centre> #  	Enter the number of the SMS centre for fixed network SMS (Send / Receive)
--	---

Meaning:

<SMS_Centre> = the telephone number of the fixed network SMS centre

Example:

You have entered the SMS-Service-Centre number **0193010** in your telecomm equipment, or this number has already been configured by factory setting. Please enter the same number in the RT3000 as the SMS centre number:

 *5 ACCCESS 0240193010#  

Your fixed network SMS equipment may expect different telephone numbers for SMS send and SMS receive. In this case enter at your fixed network SMS equipment the value for <SMS-Centre> for SMS centre (send) and the value <SMS-Centre> followed by a 0 for SMS centre (receive).



Example:

You have entered the SMS-Service-Centre number **0193010** in your SAGEM RT3000. Then enter in your fixed network SMS equipment:

- 0193010** for SMS centre send (TX)
- 01930100** for SMS centre receive (RX)

8.6.3 Configuration for fixed network SMS protocol 2

If your telephone supports fixed net SMS protocol 2, please enter the following sequence:

Default access code: 000000

* 5 A C C E S S 0 2 7 2 #	Select Fixed net SMS protocol 2
---------------------------	---------------------------------

Your fixed network SMS telephone needs two telephone numbers to exchange SMS with the SMS centre. One number to send SMS and one number to receive SMS. Choose any number and configure two numbers in both, your telephone and the RT3000. First configure the SMS centre number for sending SMS by entering the following sequence:

Default access code: 000000

* 5 A C C E S S 0 2 4 <SMS_Centre> #	Enter the number of the SMS centre to send fixed network SMS
--------------------------------------	--

Meaning:

<SMS_Centre> = the telephone number of the fixed network SMS centre

Then configure the SMS centre number for receiving SMS by entering the following sequence

Default access code: 000000



* 5 A C C E S S 0 2 6 <Local_Number> #	Enter the local number configured in your telephone to receive fixed network SMS.
--	---

Meaning:



<Local_Number> = the telephone number configured in your telephone set, to which the RT3000 delivers received SMS.

Example:

You have entered the SMS-TX number **900716800** in your telecomm equipment, or this number has already been configured by factory setting. Please enter the same number in the RT3000 as SMS centre number:

 * 5 A C C E S S 0 2 4 9 0 0 7 1 6 8 0 0 #  







You have entered the SMS-RX number **90071680** in your telecomm equipment, or this number has already been configured by factory setting. Please enter the same number in the RT3000 as local number::

 * 5 A C C E S S 0 2 6 9 0 0 7 1 6 8 0 #  

8.6.4 Enable/Disable error report





If the SAGEM RT3000 cannot deliver a SMS to the remote station, there it can send an error report to the telecomms equipment you have used to send the SMS. You can activate or deactivate this function.

Default access code: 000000

 * 5 A C C E S S 0 2 5 0 #  	Deactivate error report
 * 5 A C C E S S 0 2 5 1 #  	Activate the error report

8.7 Delete undelivered SMS

If the SAGEM RT3000 has received a SMS which cannot be delivered to the locally connected device, the LED  will blink slowly until the SMS is delivered or deleted. You can delete undelivered SMS by the following command:







 * # 1 2 #  	Deletes all received but undelivered SMS, stops blinking of the LED  .
--	---

8.8 Additional Configuration





8.8.1 Enable/Disable CLIR (Calling Line Identification Restriction)

(CLIR = Calling Line Identification Restriction) When you are making a call, your telephone number will be displayed to the called party, if there is the right equipment available.

To change the permanent setting enter the following sequence:

Default access code: 000000	Description:
 * 5 A C C E S S 0 0 7 0 #  	Phone number <u>will not</u> be displayed to called party
 * 5 A C C E S S 0 0 7 1 #  	Phone number <u>will be</u> displayed to called party







Independent from the permanent setting, you can allow or restrict the transmission of your telephone number also just for the next call. When the call is finished, the permanent setting will be active again.

	Description:
 * 3 1 # <Telnumber> ... make the call ... 	Phone number <u>will be</u> displayed to called party during this single call.
 # 3 1 # <Telnumber> ... make the call ... 	Phone number <u>will not</u> be displayed to called party during this single call.

Enter the code *31# or #31# just in front of the telephone number you like to dial.

8.8.2 Enable/Disable CLIP (Calling Line Identification Presentation)

When a call comes in and it is ringing the SAGEM RT3000 can transmit the telephone number of the calling party to the equipment connected to the **Telephone** port and the **Fax/Modem/Phone** port. This function is called CLIP - Calling Line Identification Presentation.

		Description:
 * 3 0 #	 	CLIP function activated, calling number will be transmitted.
 # 3 0 #	 	CLIP function deactivated, calling number will not be transmitted.



The SAGEM RT3000 supports CLIP transmission according to ETSI ETS 300659-1 using V.23.

8.8.3 Dialling Timeout



The SAGEM RT3000 must wait until you have dialled the complete telephone number before it will establish the connection to the remote station. To detect the end of your dialling it waits for a certain duration of time (the dial timeout) after each entered digit. If you do not enter a further digit during this dial timeout the device "thinks" that you have finished to enter the dial sequence and so it will start to establish the connection.

You can configure the duration of this period of time (dial timeout):
(Default: 600 = 6 sec.)

For the Telephone port:

Default access code: 000000		Description:
 * 5 A C C E S S 0 0 5 T T T T #	 	Dial Timeout

For the Fax/Modem/Phone port:

Default access code: 000000		Description:
 * 5 A C C E S S 0 0 6 T T T T #	 	Dial Timeout

Meaning:

T T T T = the duration of the time out :

Min value = 4 0 0 : 400 * 10 ms = 4 s

Max value = 1 2 0 0 : 1200 * 10 ms = 12 s

Recommended value: 600 (= 6 s)







Option: If activated you can stop the dial timeout by pressing # after the last entered digit of the phone number (fast dialling key). (Default: Not activated; to activate this function please see *Dialling configuration* in the section *Advanced Configuration* .)

8.8.4 Flash signal detection (used to manage two calls simultaneously)







The RT3000 is capable to detect the so called Flash signal.

On most telephone sets the Flash signal is sent by pressing the **[R]** key. In some seldom cases the length of the Flash signal of a telephone differs from the standard the SAGEM RT3000 is configured for by default. If the SAGEM RT3000 does not detect the Flash signal of your telephone in the right way please adjust the setting of the SAGEM RT3000 using the following DTMF codes:

For the Telephone port:

Default access code: 000000	Description:
 * 5 A C C E S S 0 1 4 M I N #  	Minimum duration
 * 5 A C C E S S 0 1 5 M A X #  	Maximum duration

For the Fax/Modem/Phone port:

Default access code: 000000	Description:
 * 5 A C C E S S 0 1 6 M I N #  	Minimum duration
 * 5 A C C E S S 0 1 7 M A X #  	Maximum duration

Meaning:

All Flash signals with a duration > **[M I N]** and < **[M A X]** will be detected.







With **[M I N]** = **[7]** ... **[5 5]** : that means 70 ms ... 550 ms

With **[M A X]** = **[1 2]** ... **[6 5]** : that means 120 ms ... 650 ms

8.8.5 Enable / Disable SMS Configuration

Remote configuration of you SAGEM RT3000 is possible by sending special SMS (SMS = Short Message Service) to the device.

This function can be enabled/disabled:

Default access code: 000000	Description:
 * 5 A C C E S S 0 1 8 0 #  	SMS configuration OFF
 * 5 A C C E S S 0 1 8 1 #  	SMS configuration ON (Default)

9 Installing the RT3000 modem driver on a Windows-PC

Installing the RT3000 modem driver on a Windows-PC

If you connect your PC to the SAGEM RT3000 via the RS-232 interface or via the USB interface you have the following facilities:

- access to the Internet via GPRS (page 53)
- send and receive fax (page 60)
- transmit and receive data (page 61)
- send and receive SMS (page 62)

If you connect a Personal Computer to the SAGEM RT3000 via the RS-232 interface or via the USB interface, you have to install the modem driver of the SAGEM RT3000 on the computer. When using Windows versions 2000 or XP on the computer, please make sure that no other modem drivers are or will be installed for the respective interface.

- ☞ If you connect a device to the RS-232 port of the SAGEM RT3000 and another device to the USB port of the SAGEM RT3000, the USB port has priority. That means the RS-232 port is switched off.

You want to connect the SAGEM RT3000

- to an **USB plug** of your computer, then install → 1. first the USB driver
2. then the modem driver
- to a **COM port** of your computer, then install → only the modem driver
(page 49)

Installing the driver for the USB interface

If you want to connect the SAGEM RT3000 to an USB plug of your computer, you have to do the following steps:

The computer must **NOT** be connected to the SAGEM RT3000.

1. Install the USB-driver for the SAGEM RT3000 on your computer.

This driver creates a virtual COM port on your computer that will be used by the modem driver you install afterwards.

During this process you have to install the cable connection.

2. Install the modem driver for the SAGEM RT3000.

The following instructions show dialogues that are displayed when doing the installation process on a computer running the operating system Windows XP®. If you have another Windows version (2000, ME, 98SE) do the appropriate steps.

Using Windows 2000 or Windows XP you must be logged in as **Administrator**.

Follow the instructions below and those on the screen:

1. **The SAGEM RT3000 must NOT be connected to your computer.**

Start your computer.

2. Insert the provided CD-ROM into the CD-ROM drive of your computer.
-

3. Click **Start, Execute...**

In the *Execute* dialogue click **Browse** and switch to the CD-ROM drive.

Select the installation program **setup.exe** in the directory \USB\Win2k_XP\Installer\DISK1 of the CD-ROM and click **OK** to execute this program.

Effect:

The installation program creates a folder on your hard disk and copies the required driver files to this folder.

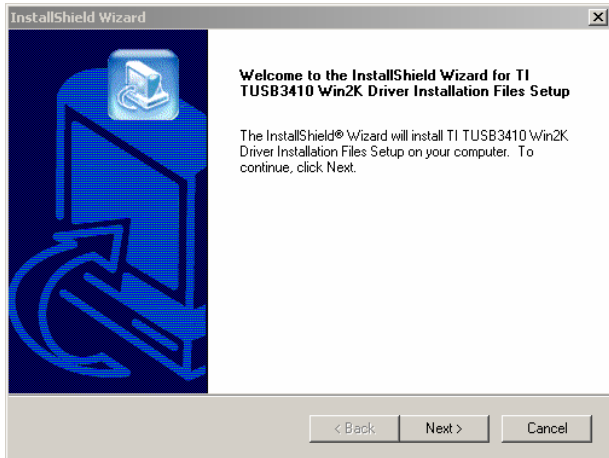

Click Next, and agree for the license agreement and click Next again.

When this dialogue is displayed:

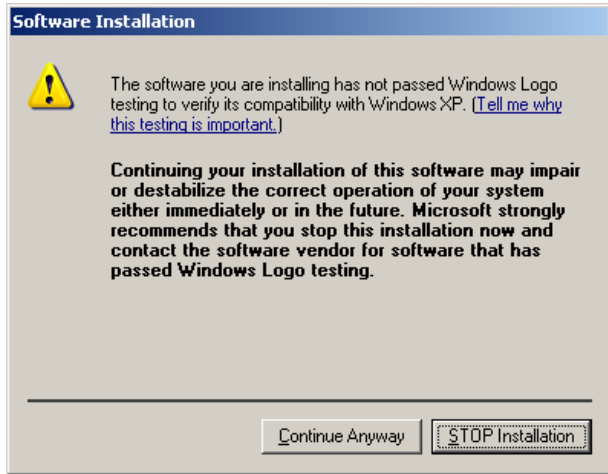

Click **Continue Anyway**.

After copying the following dialogue is displayed.

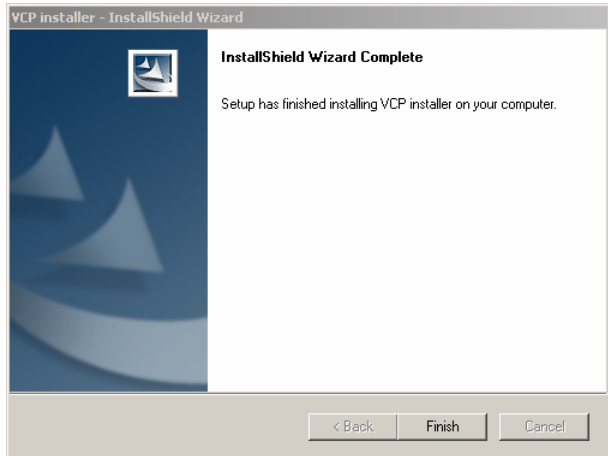

Click **Finish**

-
4. **Now connect the SAGEM RT3000 to an USB plug of your computer.**

5. When Windows detects the new device it prompts for a driver via the *Found New Hardware Wizard*:

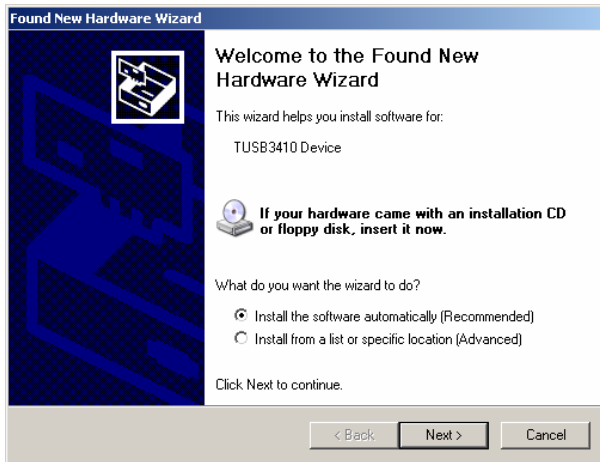

Select **Install the software automatically (Recommended)**, then click **Next >**.

The wizard starts to install the software.

When this dialogue is displayed:

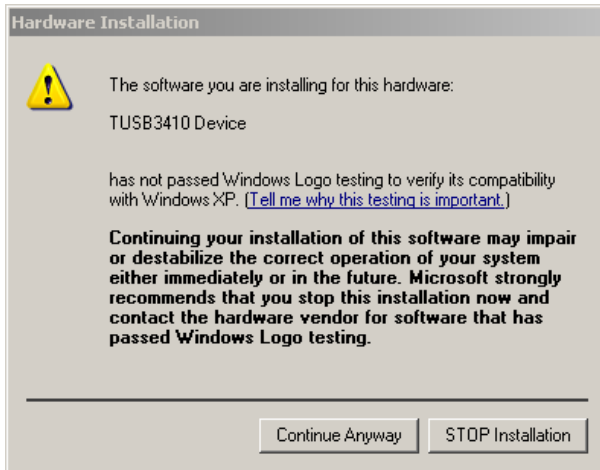

Click **Continue Anyway**.

After copying the software for the TUSB3410 Device the following dialogue is displayed.

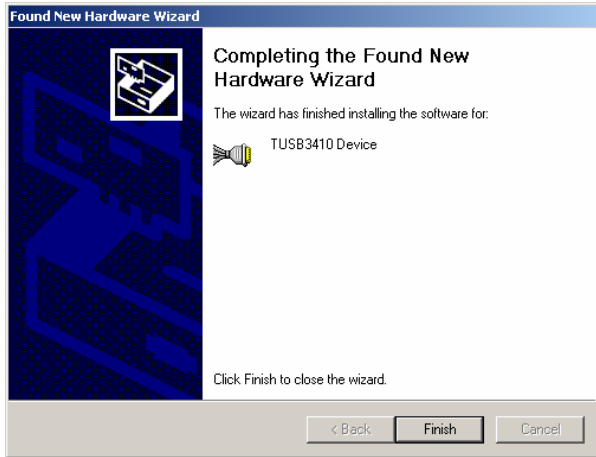

Click **Finish**.

6. Now the USB serial port will be installed.



Select **Install the software automatically (Recommended)**, then click **Next >**.

The serial port driver for the USB interface will be installed.
When this dialogue is displayed:

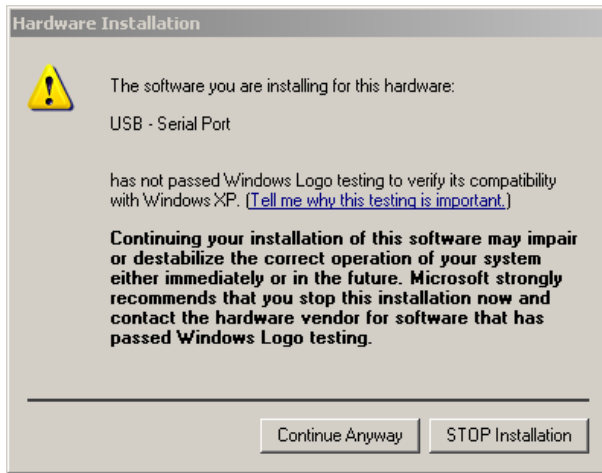

Click **Continue Anyway**.

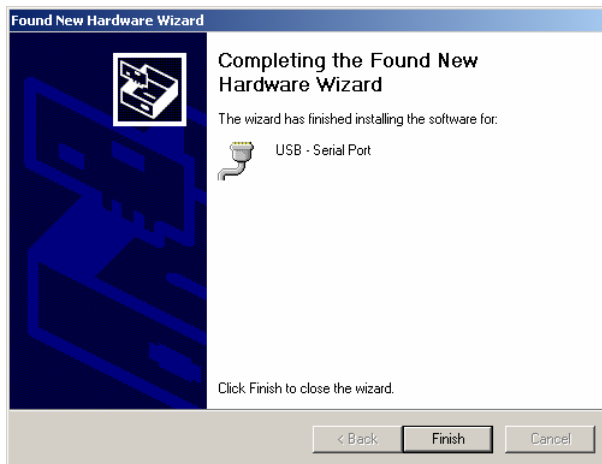

Click **Finish**.

Now your computer has an additional emulated COM port.

7. Find out what number the new COM port has.

Explanation:

Afterwards you have to install the modem driver of the SAGEM RT3000. When doing so you have to select the COM port the modem driver shall use. So you have to know: Is it COM3, COM4, COM5...?

So do the following steps:

- a) With the right mouse button click on the icon **My Computer**

on the desktop.

In the Context menu click **Properties**.

- b) In the **System Properties** dialogue select the **Hardware** card.
- c) Click on the button **Device Manager**.

The *Device Manager* dialogue is displayed:

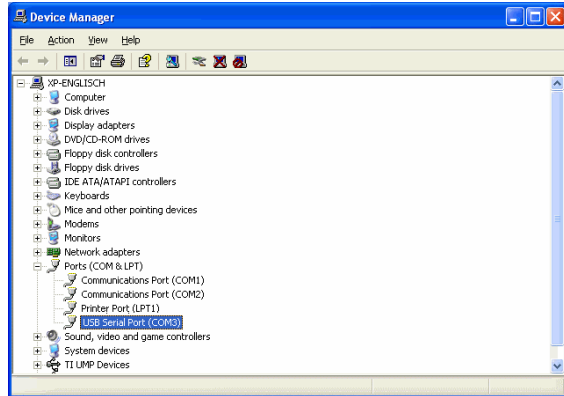

Click the +-sign next to *Ports*, if necessary.

Look for **USB Serial Port (COM...)**

Is it COM3, COM4, COM5 ...?

You want to connect the SAGEM RT3000

- to an **USB plug** of your computer, then install → 1. the USB driver (page 42)
2. the modem driver
- to a **COM port** of your computer, then install → only the modem driver

Installing the modem driver of the SAGEM RT3000

The following instructions show dialogues that are displayed when doing the installation process on a computer running the operating system Windows XP. If you have another Windows version (2000, ME, 98SE) do the appropriate steps.

Using Windows 2000 or Windows XP you must be logged in as **Administrator**. In addition please make sure that no other modem drivers are or will be installed for the respective interface.

Follow the instructions below and those on the screen:

1. Insert the provided CD-ROM into the CD-ROM drive of your computer.

-
2. Click **Start, Control Panel**

Result:

The *Control Panel* dialog appears. Choose *Classic View*.

Double-click on **Phone and Modem...**

-
3. Result: The dialog *Phone and Modem Options* is displayed.

Example:
No modem
driver is installed

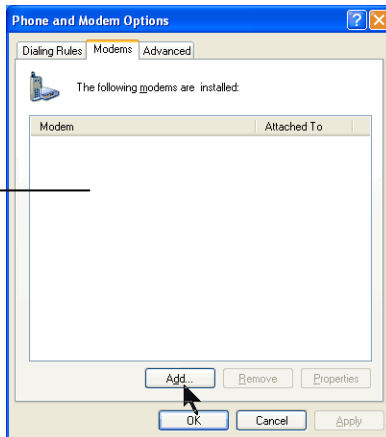

On the *Modems* card click **Add...**

4. The *Hardware Wizard* will be displayed to install a new modem. When this dialog is displayed...

Select **Don't detect my modem; I will detect it from a list**

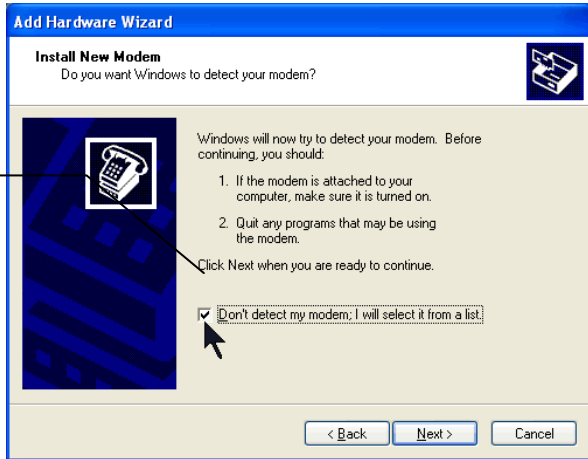

Select **Don't detect my modem; I will detect it from a list** and then click on **Next>**.

5. *Add Hardware Wizard*

Select **Have Disc...**

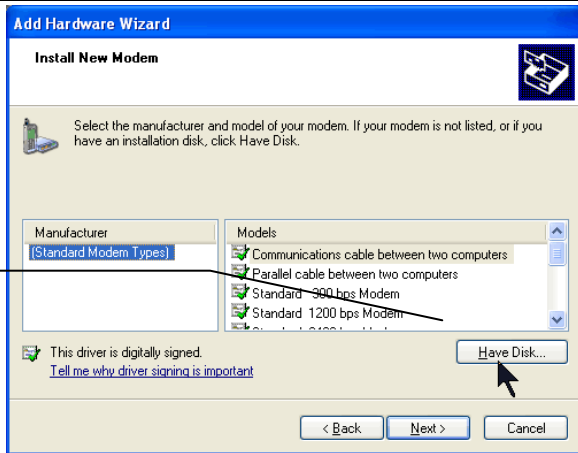

Select **Have Disc....**, then click **Next >**.

- In the next dialog change to the directory *Driver* on the CD-ROM.
Select the **Rt3000.inf** file.

Follow the instructions on the screen.



Click **Next >**.

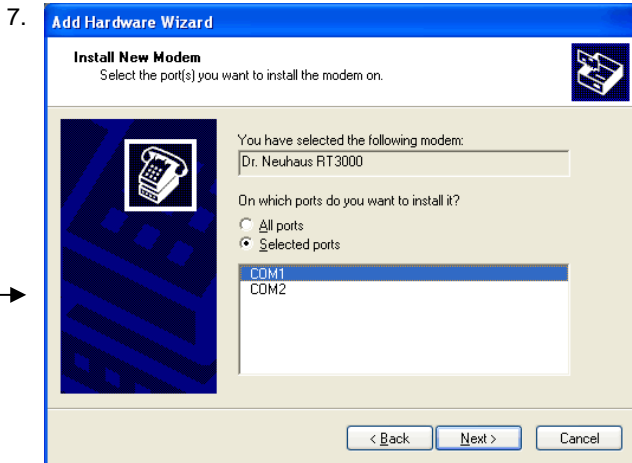

If you have installed the USB Serial Port look up the number of the created COM port → page 45.

When you are asked to choose the **COM** port, select the COM port of your computer that is connected to the SAGEM RT3000.

8. When this dialog is displayed...



Click on **Continue Anyway**

9.



Click **Finish**.

10. When the installation is finished the installed modem driver is listed in the *Phone and Modem Options* dialogue:

Example

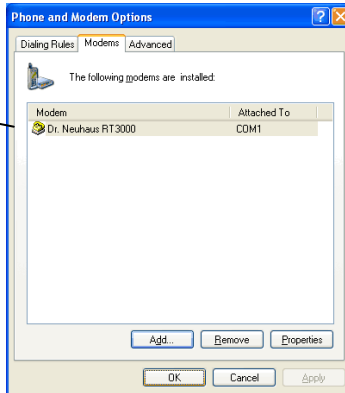

Click **OK** to close the window.

Now the device is ready for operation.

10 Operation: Internet via GPRS with a PC

- Your Personal Computer is directly connected to the SAGEM RT3000 via its RS-232 port or its USB port. Make sure that you have installed the corresponding driver (see, page 20). When you connect it to the USB port, then the RS-232 port is switched off.
- With the connected PC you have access to the Internet via the GPRS (**General Packet Radio Service**) of the GSM network. You can use Internet services like World Wide Web or E-Mail.

Precondition:

- Windows operating system (XP, 2000, ME, 98SE)
 - Installed Windows dial-up network connection configured for the GPRS connection to the Internet (see below)
 - Your GSM provider must provide the GPRS service.
- While you are using the GPRS function of the SAGEM RT3000 for example to surf in the Internet, incoming telephone calls will not be indicated.
 - The telephone number to dial-up the GPRS network is always: ***99***1#**
The APN (Access Point Name) of your GSM provider to the Internet should be predefined in the SAGEM RT3000.
You can add a new APN by entering the AT command
AT+CGDCONT=<PDP_CONTEXT> or by editing the configuration file "para.ini" see *GPRS Configuration*, page 100.

10.1 Installing the Windows dial-up network connection

The following instructions show dialogues that are displayed when doing the installation process on a computer running the operating system Windows XP. If you have another Windows version (2000, ME, 98SE) do the appropriate steps.

Preconditions You have installed the modem driver of the SAGEM RT3000. In Windows 2000 or Windows XP you must be logged in as **Administrator**.

The process

1. Click **Start, Control Panel**
The *Control Panel* dialog appears. Choose *Classic View*.
Double-click on **Network Connections**.
The *Network Connections* dialogue is displayed.
Click **Create new connection**.

2. The *New Connection Wizard* is started.



Click **Next >**.

3.

Select
Connect to Internet

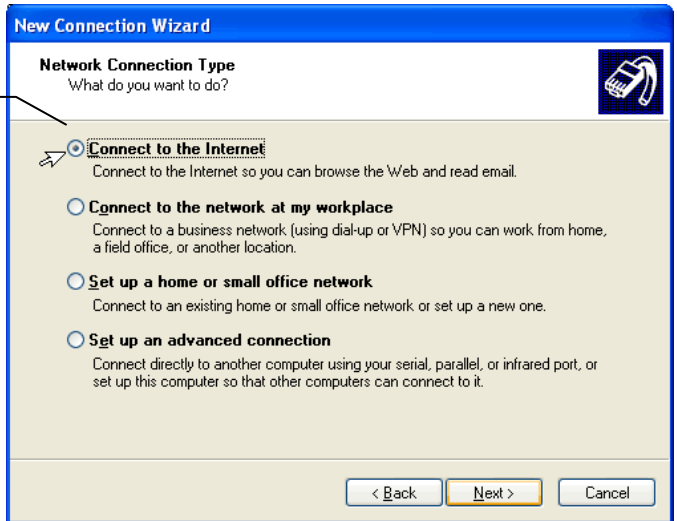

Select **Connect to Internet** and click **Next >**.

4.

Select
**Set up my
connection
manually**

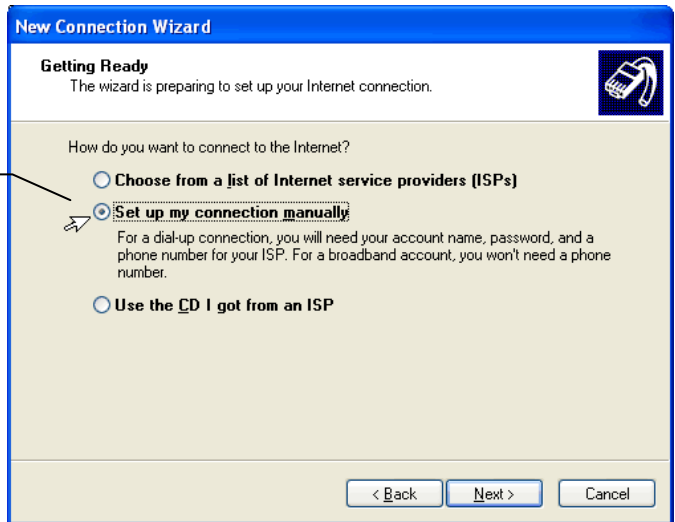

Select **Set up my connection manually** and click **Next >**.

5.

Select
**Connect using a
dial-up modem**

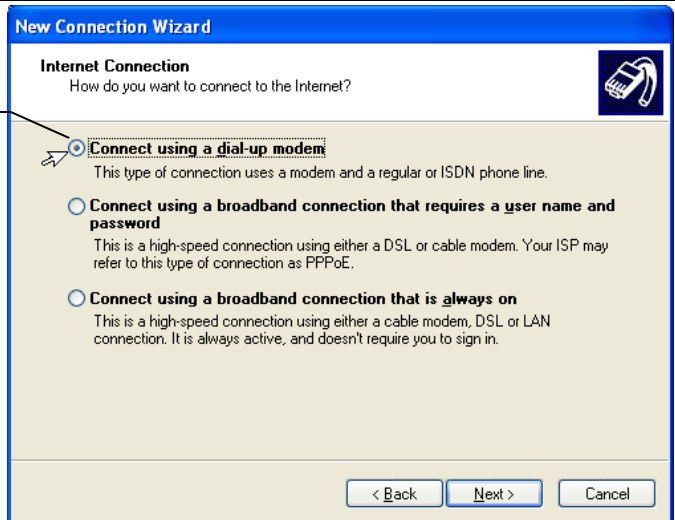

Select **Connect using a dial-up modem** and click **Next >**.

6. If prompted to select the modem select:
Dr. Neuhaus RT3000.

7.

The screenshot shows a dialog box titled "New Connection Wizard" with a blue header. Below the header, the text "Connection Name" is followed by the question "What is the name of the service that provides your Internet connection?". To the right is a small icon of a mobile phone. Below this, the instruction "Type the name of your ISP in the following box." is followed by the label "ISP Name" and a text input field containing "GSM GPRS Internet Service Provider". Below the input field, it says "The name you type here will be the name of the connection you are creating." At the bottom right, there are three buttons: "< Back", "Next >" (highlighted with a yellow border), and "Cancel".

Write any name that describes the purpose of the Dial-up connection. Then click **Next >**.

8.

The screenshot shows a dialog box titled "New Connection Wizard" with a blue header. Below the header, the text "Phone Number to Dial" is followed by the question "What is your ISP's phone number?". To the right is a small icon of a mobile phone. Below this, the instruction "Type the phone number below." is followed by the label "Phone number:" and a text input field containing "*99***1#". Below the input field, it says "You might need to include a '1' or the area code, or both. If you are not sure you need the extra numbers, dial the phone number on your telephone. If you hear a modem sound, the number dialed is correct." At the bottom right, there are three buttons: "< Back", "Next >" (highlighted with a blue border), and "Cancel".

*99***1#

Enter the phone number for access to the Internet: ***99***1#**
Then click **Next >**.

9.

New Connection Wizard

Internet Account Information
 You will need an account name and password to sign in to your Internet account.

Type an ISP account name and password, then write down this information and store it in a safe place. (If you have forgotten an existing account name or password, contact your ISP.)

User name:

Password:

Confirm password:

Use this account name and password when anyone connects to the Internet from this computer

Make this the default Internet connection

Turn on Internet Connection Firewall for this connection

< Back Next > Cancel

Enter your user name and password.

Look them up in your subscription. Or ask your GSM telephone company.

Click **Next >**.

10.

New Connection Wizard

Completing the New Connection Wizard

You have successfully completed the steps needed to create the following connection:

GSM GPRS Internet Service Provider

- Make this the default connection
- This connection is firewalled
- Share with all users of this computer
- Use the same user name & password for everyone

The connection will be saved in the Network Connections folder.

Add a shortcut to this connection to my desktop

To create the connection and close this wizard, click Finish.

< Back Finish Cancel

Click **Finish**. The installation of the dial-up network connection to the Internet is done.

For Windows 98 users...

By default Windows 98 will use the local area code when dialling the *99***1# number to establish the Internet connection.

To prevent this do the following:

In the *Dial-up Network* dialogue (Double-click the icon **My Computer**, then the icon **Dial-up Network**) the installed Dial-up network connection via the SAGEM RT3000 is represented by an icon.



1. a) Click on the icon with the right mouse button.
b) In the context menu select **Properties**.

2. In the displayed dialogue select that the local area code is not to be used.

DNS server address configuration

If you like to enter „common“ Internet addresses (i.e. www.sagem.com), when surfing the World Wide Web with your Internet browser, you need to configure before a DNS server address.

To configure the DNS server address, please do the following steps:

1. Open the **Properties** dialogue of the *Dial-up Network* installed before for the SAGEM RT3000.
2. Depending on the used operating system you will find fields to enter the address of a Primary and a Secondary DNS server under **TCP/IP settings** or **Networking**. Enter at least the address of a Primary DNS server.

Your GSM/GPRS operator will tell you the DNS server addresses. Check the documents you have received with your SIM card, have a look to the operator's WEB side or call the Hotline.

10.2 To connect and disconnect to/from the GPRS / Internet

To connect

1. Double-click the icon that represents the connection.

Result:

The dialog for establishing the connection appears.

2. 

Click **Dial**.



When the connection is established an icon appears down on the right side of the screen representing the connection.

To use Internet services you can use the suitable software, for example your browser or your E-Mail program.

To disconnect

1. Click on the icon representing the active connection (down on the right side of the screen) with the right mouse button to open the context menu.
-
2. In the context menu click **Disconnect**.

11 Operation: Using a PC to send and receive fax

- Your Personal Computer is directly connected to the SAGEM RT3000 via its RS-232 port or its USB port. Make sure that you have installed the modem driver of the SAGEM RT3000 (see, page 20). When you connect your PC to the USB port, then the RS-232 port is switched off.
- With the fax software installed on your computer you can send and receive fax documents. The remote fax machine may be any facsimile device. Your fax software must be compatible to fax class 1.
- While you are sending or receiving a fax with your PC, the single “wireless” telephone line of the SAGEM RT3000 will be engaged. You cannot make a telephone call or send / receive a fax with your analogue facsimile device at the same time.
- By default a received fax comes in at the **Fax/Modem/Phone** port of the SAGEM RT3000, so that a facsimile device connected to this port receives the fax. If you want to receive fax documents by the PC connected to the SAGEM RT3000, you have to make the corresponding setting. See **Select Port for Fax Calls**, page 34.

12 Operation: Using a PC to transmit and receive data

- Your Personal Computer is directly connected to the SAGEM RT3000 via its RS-232 port or its USB port. Make sure that you have installed the modem driver of the SAGEM RT3000 (see, page 42). When you connect your PC to the USB port, then the RS-232 port is switched off.
- The SAGEM RT3000 is functioning like a GSM modem. The called party can be a GSM modem or a fixed network modem.
If the called party's modem is connected to the fixed network, it must support 9600 bps (V.32) / V.42 for the connection into the fixed network. This is necessary for the communication to the GSM network.
- To use the GSM modem functions of the SAGEM RT3000 for data communication you can use any terminal program, e. g. *HyperTerminal*.
Like an analogue modem the SAGEM RT3000 is controlled by AT commands. You will find a list of the AT commands on page 63.
- By default an incoming data call comes in at the **Fax/Modem/Phone** port of the SAGEM RT3000, so that a device connected to this port gets the call. If you want to receive data calls by the PC connected to the SAGEM RT3000, you have to make the corresponding setting. See **Select Port for Data Calls**, page 35.

Data communication with a terminal program

On the computer start any terminal program which you normally use for data transfer, e.g. *HyperTerminal*.

To set up the connection you have to know:

- the telephone number of the remote party
- *RT3000* is the device for making the connection.
-

Be sure that the following connection settings are enabled:

Transmission speed:	57,600 bps
Data bits:	8
Parity:	N (none)
Stop bits:	1

You can either control the GSM-Gateway directly using AT commands (see page 64) or perform the functions via menu commands of your Terminal program (e. g. *HyperTerminal*). Where not specified otherwise the commands are executed on accordance with the V.25ter convention.

13 Operation: Using a PC to send and receive SMS

- Your Personal Computer is directly connected to the SAGEM RT3000 via its RS-232 port or its USB port. Make sure that you have installed the modem driver of the SAGEM RT3000 (see, page 20). When you connect your PC to the USB port, then the RS-232 port is switched off.
- With a SMS-Software running on a PC connected to the SAGEM RT3000, you can send and receive SMS (Short Message Service).
The SMS-Software must support the SMS AT commands listed in chapter 0.
- By default an incoming SMS enters like any data call at the **PC**-port of the SAGEM RT3000. So you can receive SMS by the PC connected at the RS-232 or USB port of the SAGEM RT3000. If you want you can change this setting. See *Select port to receive SMS*, page 35.

14 For experienced Users: AT commands

14.1 AT Command Interface

The SAGEM RT3000 has an AT command interface. Using a terminal program like *HyperTerminal* (belongs to Windows) on your PC you can

- communicate with a remote party (see *Operation: Using a PC to transmit and receive data*, page 61) and
- configure the SAGEM RT3000.

Configuration of the SAGEM RT3000 by AT commands • On the computer start any terminal program which you normally use for data transfer, e.g. *HyperTerminal*.

Be sure that the following connection settings are enabled:

Transmission speed:	57,600 bps
Data bits:	8
Parity:	N (none)
Stop bits:	1

There must not be any connection to a remote party so that the SAGEM RT3000 is in command mode.

Enter the appropriate AT commands to configure the SAGEM RT3000.

To switch echo on so that all entered characters are displayed on the screen enter: ATE1

14.2 AT commands supported by the SAGEM RT3000

Default settings are printed **Bold**.

Command	Function (factory setting in bold print)												
ATA	Accept call												
ATB[n]	Setting of the transfer parameter <i>n</i> for data connections. Options for <i>n</i> : <table style="margin-left: 20px;"> <tr><td>7</td><td>2400 bps, asynchronous, V.22bis</td></tr> <tr><td>11</td><td>4800 bps, asynchronous, V.32</td></tr> <tr><td>13</td><td>9600 bps, asynchronous, V.32</td></tr> <tr><td>25</td><td>2400 bps, asynchronous, V.110 ISDN</td></tr> <tr><td>27</td><td>4800 bps, asynchronous, V.110 ISDN</td></tr> <tr><td>29</td><td>9600 bps, asynchronous, V.110 ISDN</td></tr> </table>	7	2400 bps, asynchronous, V.22bis	11	4800 bps, asynchronous, V.32	13	9600 bps, asynchronous, V.32	25	2400 bps, asynchronous, V.110 ISDN	27	4800 bps, asynchronous, V.110 ISDN	29	9600 bps, asynchronous, V.110 ISDN
7	2400 bps, asynchronous, V.22bis												
11	4800 bps, asynchronous, V.32												
13	9600 bps, asynchronous, V.32												
25	2400 bps, asynchronous, V.110 ISDN												
27	4800 bps, asynchronous, V.110 ISDN												
29	9600 bps, asynchronous, V.110 ISDN												
ATD[n] [;] [x]	Dial number Parameters: <i>n</i> = String of dialling digits and optionally V.25ter modifiers (dialling digits): 0-9, *, #, +, A, B, C ; Only required to set up voice calls. The device remains in command mode. x =: i Activates CLIR (disables presentation of own phone number to called party) I Deactivates CLIR												
ATE[n]	Command echo Parameters: <i>n</i> = 0 : Echo mode off 1: Echo mode on												
ATH[n]	Hang up Parameters: <i>n</i> = 0: Terminate call												
ATI[n]	Output product code <table style="margin-left: 20px;"> <tr><td>0</td><td>'RT-3000 DNT8115'</td></tr> <tr><td>3</td><td>'Firmware Version: 1.004'</td></tr> <tr><td>4</td><td>'GSM-Module-Firmware: SAGEM JE3,7D'</td></tr> <tr><td>8</td><td>Output supported operating modes (see ATB)</td></tr> <tr><td>9</td><td>Identification of the modem and the mobile phone</td></tr> </table>	0	'RT-3000 DNT8115'	3	'Firmware Version: 1.004'	4	'GSM-Module-Firmware: SAGEM JE3,7D'	8	Output supported operating modes (see ATB)	9	Identification of the modem and the mobile phone		
0	'RT-3000 DNT8115'												
3	'Firmware Version: 1.004'												
4	'GSM-Module-Firmware: SAGEM JE3,7D'												
8	Output supported operating modes (see ATB)												
9	Identification of the modem and the mobile phone												
ATQ[n]	Specifies whether or not the device transmits any result code to the connected TE. Information text transmitted in response is not affected by this setting. Parameters: <i>n</i> = 0 : result codes transmitted by TA 1: no result code transmitted by TA												
ATS0= <i>n</i>	Writes value <i>n</i> into status register 0. Set number of rings before automatically answer the call. This command is valid only for data calls. Parameters:												

Command	Function (factory setting in bold print)
	n = 0 : automatic answering deactivated 1-255: number of rings before automatically answering
ATS0?	Displays the value of status register 0
ATS3= <i>n</i>	Writes the value <i>n</i> into status register 3. This parameter determines the character recognised by TA to terminate an incoming command line (13 = <CR> by default). Parameters: n= 0 – 127 : command line termination character
ATS3?	Displays the value of status register 3
ATS5= <i>x</i>	Writes the value X into status register 5. Determines the command line editing character (8 =<Backspace> by default). Parameters: n= 0 – 127 : command line editing character
ATS5?	Displays the value of status register 5
ATV[<i>n</i>]	Set result code format mode. This parameter setting determines the contents of the header and trailer transmitted with result codes and information responses. Parameters: n = 0 Information response: <text><CR><LF> Short result code format: <numeric code><CR> 1 Information response: <CR><LF><text><CR><LF> Long result code format: <CR><LF><verbose code><CR><LF>
ATZ	Load standard configuration
AT&C[<i>n</i>]	Set circuit Data Carrier Detect (DCD) function mode. Parameters: n = 0 : DCD line is always ON 1 : DCD line is ON in the presence of data carrier only (Default).
AT&D[<i>n</i>]	Set circuit Data Terminal Ready (DTR) function mode. Parameters: n = 0: TA ignores status on DTR. 1 : ON->OFF on DTR: Change to command mode while retaining the connected call. 2 : ON->OFF on DTR: Disconnect call, change to command mode. During state DTR = OFF is auto-answer off. (Default)
AT&F	Load factory setting for the AT commands &K, &C, &D, E, Q, V, S0, S3, S5, +CNMI, +CMGF
AT&k[<i>n</i>]	Local data flow control (DTE ⇔ DCE)
&k0	Data flow control OFF

Command	Function (factory setting in bold print)
&k3	Data flow control RTS/CTS
AT&V	Displays current configuration
AT&W	Save configuration
A/	Repeat previous command line
AT+FCLASS= <i>n</i>	Setting the Faxclass Parameters: <i>n</i> = 0 : normal operation 1: PC Fax enabled
AT+CGATT= <i>n</i>	PS attach or detach Parameters: <i>n</i> = 0 detached 1 attached
AT+CGDCONT= 1, "IP", "<APN>", "0.0.0.0", 0,0	Define PDP context. <APN> = Access Point Name Name of the access point into the Internet oder Intranet
AT+CPIN= <i>PIN</i>	Enter the PIN number of the SIM card
AT+CCLK= <i>time</i>	Set real time clock. <i>time</i> = string type value; format is "yy/MM/dd,hh:mm:ss", where characters indicate year (two last digits), month, day, hour, minutes, seconds
AT+CCLK?	Displays the time: +CCLK: <i>time</i> (see above)
AT+CGMI	Request manufacturer identification
AT+CGMM	Request model identification
AT+CGMR	Request revision identification
AT+CPWD= <i>fac,old pw,newpw</i>	Change Password <i>fac</i> is the type of password, fix value "SC" (for SIM PIN) <i>oldpw</i> shall be the same old password specified for the facility <i>newpw</i> is the new password;
AT+CPWD=?	Displays integer type maximum length of the password for the facility: Response: +CPWD: ("SC", 8)
AT+CREG?	Check network registration Answer: +CREG=<n>,<stat>,<lac>,<ci> Parameters: <n>: 0: network registration unsolicited result code disabled <stat>: 0: not registered, ME is not currently searching a new operator to register to 1: registered, home network 2: not registered, but ME is currently searching a new operator to register to

Command	Function (factory setting in bold print)
	3: registration denied 4: unknown 5: registered <lac>: string type; two byte location area code in hexadecimal format (e.g. "00C3" equals 195 in decimal) <ci>: string type; two byte cell ID in hexadecimal format
AT+CCFC= <i>reas</i> , <i>mode</i> [, <i>number</i> [, <i>type</i> [, <i>class</i> [, <i>subaddr</i> [, <i>satype</i> [, <i>time</i> [, <i>status</i>]]]]]]	Call forwarding number and conditions control <i>reas</i> = 0: unconditional 1: mobile busy 2: no reply 3: not reachable 4: all call forwarding 5: all conditional call forwarding <i>mode</i> = 0 disable 1 enable 2 query status 3 registration 4 erasure <i>number</i> = string type phone number of forwarding address in format specified by <i>type</i> <i>type</i> = type of address octet in integer format <i>class</i> = is a sum of integers each representing a class of information (default 1) 1: voice 2: data 4: fax <i>subaddr</i> string type subaddress of format specified by <i>satype</i> <i>satype</i> type of subaddress octet in integer format <i>time</i> 1...30 when "no reply" is enabled or quired, this gives the time in seconds to wait before call is forwarded (default value is 20) <i>status</i> 0: not active 1: active

Command	Function (factory setting in bold print)
AT+CSQ	Displays the Signal Quality Parameters: <i>rssi</i> = 0 -113 dbm or less 1 -111 dbm 2...30 -109... -53 dbm 31 -51 dbm or greater 99 not known or not detectable <i>ber</i> = (in percent) 0...7 as RXQUAL values in the table in GSM 05.08 [20] subclause 8.2.4 99 not known or not detectable
AT+CNUM	Displays Subscriber Number
AT+CIMI	Request international mobile subscriber identity
AT+CGSN	Request product serial number identification
AT+CGQREQ=[<i>cid</i> [, <i>precedence</i> [, <i>delay</i> [, <i>reliability</i> [, <i>peak</i> [, <i>mean</i>]]]]]	This command specifies a Quality of Service Profile that is used when the device sends an Activate PDP Context Request message to the network. If a value is omitted for a particular class then the value is considered to be unspecified. <i>cid</i> = a numeric parameter which specifies a particular PDP context definition (see the +CGDCONT and +CGDSCONT commands) <i>precedence</i> = a numeric parameter which specifies the precedence class <i>delay</i> = a numeric parameter which specifies the delay class <i>reliability</i> = a numeric parameter which specifies the reliability class <i>peak</i> = a numeric parameter which specifies the peak throughput class <i>mean</i> = a numeric parameter which specifies the mean throughput class

Command	Function (factory setting in bold print)
AT+CGQMIN= [<i>cid</i> [, <i>precedence</i> [, <i>delay</i> [, <i>reliability</i> [, <i>peak</i> [, <i>mean</i>]]]]]]	<p>Quality of Service Profile (Minimum acceptable)</p> <p><i>cid</i> = a numeric parameter which specifies a particular PDP context definition (see the +CGDCONT and +CGDSCONT commands)</p> <p><i>precedence</i> = numeric parameter for the precedence class</p> <ul style="list-style-type: none"> 0: network subscribed value 1: High Priority Service commitments shall be maintained ahead of precedence classes 2 and 3 2: Normal priority Service commitments shall be maintained ahead of precedence class 3 3: Low priority <p><i>delay</i> = numeric parameter for the delay class</p> <p><i>reliability</i> = numeric parameter for the reliability class</p> <ul style="list-style-type: none"> 0: network subscribed value 1: Non real-time traffic, error-sensitive application that cannot cope with data loss 2: Non real-time traffic, error-sensitive application that can cope with infrequent data loss 3: Non real-time traffic, error-sensitive application that can cope with data loss, GMM/SM, and SMS 4: Real-time traffic, error-sensitive application that can cope with data loss 5: Real-time traffic, error non-sensitive application that can cope with data loss <p><i>peak</i> = numeric parameter for the peak throughput class</p> <ul style="list-style-type: none"> 0: network subscribed value 1: Up to 1000 (8 kbit/s) 2: Up to 2000 (16 kbit/s) 3: Up to 4000 (32 kbit/s) 4: Up to 8000 (64 kbit/s) 5: Up to 16000 (128 kbit/s) 6: Up to 32000 (256 kbit/s) 7: Up to 64000 (512 kbit/s) 8: Up to 128000 (1024 kbit/s) 9: Up to 256000 (2048 kbit/s) <p><i>mean</i> = a numeric parameter which specifies the mean throughput class</p>

Command	Function (factory setting in bold print)
AT+CBST= [<i>speed</i> [, <i>name</i> [, <i>ce</i>]]]	<p>Select bearer service type. This command selects the bearer service <i>name</i> with data rate <i>speed</i>, and the connection element <i>ce</i> to be used when data calls are originated.</p> <p><i>speed</i> =</p> <ul style="list-style-type: none"> 0 autobauding (automatic selection of the speed; this setting is possible in case of 3.1 kHz modem and non-transparent service) 4 2400 bps (V.22bis) 6 4800 bps (V.32) 7 9600 bps (V.32) 68 2400 bps (V.110 or X.31 flag stuffing) 70 4800 bps (V.110 or X.31 flag stuffing) 71 9600 bps (V.110 or X.31 flag stuffing) <p><i>name</i> =</p> <ul style="list-style-type: none"> 0 data circuit asynchronous (UDI or 3.1 kHz modem) 1 data circuit synchronous (UDI or 3.1 kHz modem) <p><i>ce</i> =</p> <ul style="list-style-type: none"> 0 transparent 1 non-transparent <p>The values given in the parameter file para.ini, section Mobile_Config, Bearer_Service will be used as factory default values. If there are no values given, the setting 7,0,1 will be used until the values will be modified by using AT+CBST or by modifying the para.ini directly.</p>

14.2.1 AT Command Interface (SMS)

SMS	
+CMGD	See below.
+CMGF	See below.
+CMGL	See below.
+CMGR	See below.
+CMGS	See below.
+CMGW	See below.
+CMSS	See below.
+CNMI	See below.
+CPMS	See below.
+CSCA	See below.
+CSMP	See below.

AT+CMGD – Deleting a message:

AT+CMGD=<index>	Deletes the message
-----------------	---------------------

<i>Values for:</i> <index> 1 – n	Message storage location Message storage location on SIM, n depends on SIM card capacity
-------------------------------------	--

AT+CMGF – Setting Text / PDU mode:

AT+CMGF=[<mode>]	Sets the mode
AT+CMGF?	Calls up the current mode
AT+CMGF=?	Lists the modes supported
<i>Values for:</i> <mode> 0 1	PDU mode Text mode

AT+CMGL – Listing the stored messages:

AT+CMGL[=<stat>]	Lists the messages according to various characteristics
AT+CMGL=?	Shows the message display options supported
<i>Values for:</i> <stat> 0 1 2 3 4	Message status „REC UNREAD“ (Messages received but unread) „REC READ“ (Messages received and read) „STO UNSENT“ (Messages stored but not sent) „STO SENT“ (Messages stored and sent) „ALL“ (All types of message)

AT+CMGR – reading a message:

AT+CMGR=<index>	Reads the message
<i>Values for:</i> <index> 1 – 10	Message storage location Message storage location on SIM, n depends on SIM card capacity

AT+CMGS – Sending a message

Text Mode activated (AT+CMGF=1)

AT+CMGS=<da><CR> <Ttxt> <CTRL Z>	Sends the message
<i>Value for:</i> <da>	“Recipient’s telephone number”
<i>Value for:</i> <Ttxt>	The text to be sent

AT+CMGS – Sending a message:

PDU mode activated(AT+CMGF=0)

AT+CMGS=<length><CR> coded PDU text <CTRL Z>	Sends the message
<i>Value for:</i> <length>	No. of PDU characters

AT+CMGW – Writing a message into memory:

Text Mode activated (AT+CMGF=1)

AT+CMGW=<oa/da><CR> <Ttxt> <CTRL Z>	Writes the message into the memory
<i>Value for:</i> <oa/da>	“Recipient’s telephone number”
<i>Value for:</i> <Ttxt>	The text to be sent

AT+CMGW – Writing a message into memory:

PDU mode activated(AT+CMGF=0)

AT+CMGW=<length>[,<stat>]<CR> coded PDU text <CTRL Z>	Writes the message into the memory
<i>Value for :</i> <length>	No. of PDU characters

AT+CMSS – Sending a SMS message from memory:

AT+CMSS=<index>[,<da>]	Sends the SMS message from the memory
<i>Values for:</i> <index> 1 – 10	SMS storage location Message storage location, n depends on SIM card capacity
<i>Values for:</i> <da>	“Recipient’s telephone number”

AT+CNMI – New SMS message indication:

AT+CNMI= [<mode>][,<mt>][,<bm>] [,<ds>][,<bfr>]	Indicates new SMS message
AT+CNMI?	Response: +CNMI: <mode>,<mt>,<bm>,<ds>,<bfr>
AT+CNMI=?	Lists the options
<i>Values for:</i> <mode> 0 1	Buffer unsolicited result codes in the device. If ist buffer is full, indications can be buffered in some other place or the oldest indications may be discarded and replaced with new received indications. Not supported

	2	Buffer unsolicited result codes in the TA when TA-TE link is reserved (e. g. in online data mode) and flush them to the TE after reservation. Otherwise forward them directly to the TE.
	3	Not supported
<i>Values for:</i>	<mt>	
	0	No SMS-DELIVER indications are routed to the TE.
	1	If SMS-DELIVER
	2	Not supported
	3	Not supported
<i>Values for:</i>	<bm>	
	0	No CBM indications are routed to the TE.
	1	Not supported
	2	New CBMs are routed directly to the TE using unsolicited result code: CBM: <length><CR><LF><pdu> (PDU mode enabled) or +CBM: <sn>, <mid>, <dc>, <page>, <pages> <CR><LF><data> (text mode Enabled).
	3	Class 3 CBMs are routed directly to TE using unsolicited result codes defined in <bm>=2.
<i>Values for:</i>	<ds>	
	0	No SMS-STATUS-REPORTs are routed to the TE.
	1	Not supported
	2	Not supported
	<bfr>	
	0	The buffered notification are sent.
	1	Not supported

AT+CPMS – Selecting the SMS memory location:

AT+CPMS= <mem>	Sets the memory location
AT+CPMS?	Calls up the current memory location
AT+CPMS=?	Lists the memory locations supported
<i>Values for:</i> <mem> „MT“	Device

AT+CSCA – Setting the Service Center address:

AT+CSCA=<sca>[,<tosca>]	Sets the Service Center address
AT+CSCA?	Displays the address currently set
AT+CSCA=?	Lists the characters allowed for the telephone number
<i>Value for:</i> <sca>	"Service Center telephone number"
<i>Value for:</i> <tosca>	129, 145

AT+CSMP – Setting the text mode parameters:

AT+CSMP=[<fo>[,<vp>[,<pid>[,<dc>]]]]	Sets the parameters
AT+CSMP?	Calls up the current settings
AT+CSMP=?	Response "OK"
<i>Values for:</i> <fo>	17
<i>Values for:</i> <vp>	Message storage time in the SMS Center
71	6 hours
167	24 hours
173	7 days
255	63 weeks
<i>Value for:</i> <pid>	0
<i>Value for:</i> <dc>	0

14.2.2 AT Command Interface (SIM APPLICATION TOOLKIT)

SIMTOOLKIT	
+KSTC	See below
+KSTE	See below
+KSTER	See below
+KSTF	See below
+KSTIA	See below
+KSTIR	See below
+KSTIS	See below
+KSTP	See below
+KSTR	See below
+KSTV	See below

In addition to the listed AT commands, in this operating mode the GSM-Adapter recognises, accepts and acknowledges a series of AT commands which are, however, not executed. These commands are:

ATL*n*, ATM*n*, ATX*n*, ATP, ATT

AT+KSTIA – Access to an instance of an icon

AT+KSTIA=<action>,<icon id>,<instance>		Access an instance of a given icon identifier
	Response: If <action>=1: +KSTIA:<icon id>,<instance>,<num>,<size> If <action>=0: OK	
<i>Values for:</i>	<action>	1 To ask the device to initiate the read of the Image Instance Data File corresponding to the <instance> of the <icon id>. 0 To tell the device that the transfer from the device to the DTE is finished
	<icon id>	integer type; icon identifier of the icon
	<instance>	integer type; instance number selected for this icon
	<num>	integer type; number of data blocks for the current instance
	<size>	integer type; maximum size of one block

AT+KSTIR – Get a data block of an icon instance

AT+KSTIR=<num>		Sets the parameters
	Response: +KSTIR:<data>,<checksum> OK	
<i>Values for:</i>	<num>	Integer type; block number
	<data>	string type (in HEX format); data block
	<checksum>	string type (in HEX format)

AT+KSTIS – Retrieve the icon

AT+KSTIS		Sets the parameters
	Response: +KSTIS:<num>,<details1>[,...<detailsi>] OK	
<i>Values for:</i>	<icon id>	Integer type; icon identifier of the icon
	<num>	integer type; number of instances for this icon
	<details1>...<detailsi>	String type in (HEX format) instance number image instance width (in pixel) image instance height (in pixel) image coding scheme ('11', '21' ...) length of image instance data (in bytes)

AT+KSTP – Profile supported by DTE

AT+KSTP=?		Test command
	Response: +KSTP:<support>,<setup profile> OK	
AT+KSTP?		Read command
	Response: +KSTP:<current profile>,<default profile> OK	
AT+KSTP=<support>[,<DTE profile>]		Write command
	Response: OK	
<i>Values for:</i>	<support>	0 No SIM Application Toolkit support 1 SIM Application Toolkit support
	<xxx profile>	Profile in HEX format

AT+KSTR – Terminal Response

AT+KSTR=?	Test command
	Response: +KSTR: (list of supported <type of responses> OK
AT+KSTR=<type of response>,<TLVs>	Write command
	Response: OK
Values for: <type of response>	0 final response (other values will be added later)
<TLVs>	TLVs in HEX format

AT+KSTV – Envelope command

AT+KSTV=<envelope>	Sets the parameter.
	Response: OK
Values for: <envelope>	TLVs in HEX format

15 Configuration methods

The complete configuration of the SAGEM RT3000 is written in a parameter file called *para.ini* which is stored in the non-volatile memory of the device. When configuring the SAGEM RT3000, the parameter file *para.ini* will be modified. The SAGEM RT3000 can be configured by following methods:

- Local configuration by entering DTMF codes (using a telephone set). Using this method the user can change only those parameters that are changed most often. He cannot set all parameters by this method.
- Loading the configuration file **para.ini** on the local or a remote PC by a FTP program, then editing the file **para.ini** with a text editor and then upload the edited file back to the device.
- Remote configuration by sending configuration SMS.
- Sending AT commands using a Terminal program on the local PC

Local configuration:

by DTMF codes
(using a telephone)

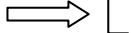

by editing the config.
file para.ini
(download and
upload by FTP)

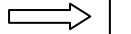

by sending AT
commands

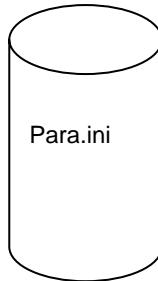
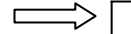

Remote configuration:



by SMS



by editing the config.
file para.ini
(download and
upload by FTP)

To understand the various configuration methods you have to know how the parameters to be set are identified. So let's have a look in an excerpt of the file *para.ini*:

See a sample file *para.ini* on page 108.

Excerpt of the file *para.ini*:

[DIALING]

;settings for channel a

CHA_FAST_DIAL=NO

CHA_DIAL_TIMEOUT=600

CHA_LOCAL_CALL_WAIT=NO

CHA_LOCAL_CALL_CTRL=NO

CHA_TX_VOICE_LEVEL=-7

CHA_RX_VOICE_LEVEL=-7

SECTION

The file *para.ini* consists of various sections.

Comment that gives instructions to the user

PARAMETER

This is the name of the parameter to be set.

VALUE

This is the value for the parameter. Note the equotation mark (=) between parameter and value. No blank!

The parameters that can be set by DTMF codes (using a telephone set) are also identified by a command ID that is not listed in the *para.ini*.

Nomenclature:

- ➔ Port A is the configuration name for the **Telephone** port.
- ➔ Port B is the configuration name for the **Fax/Modem/Phone** port.
- ➔ Port C is the configuration name for the **PC** port (through USB or RS232).

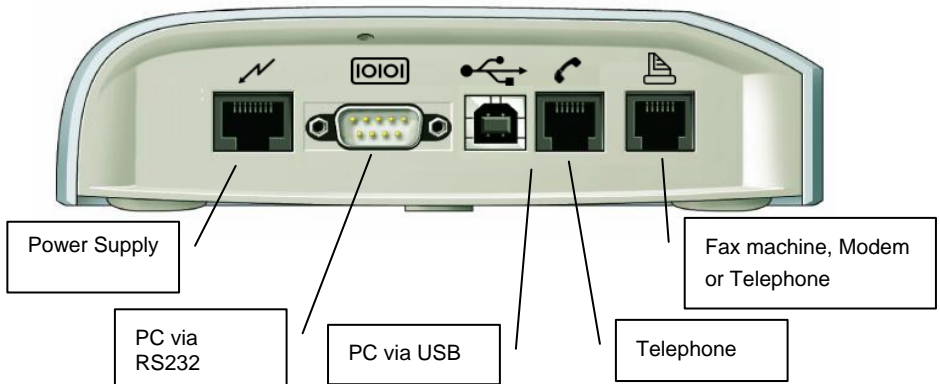

15.1 Configuration by DTMF

The parameter values in *para.ini* may be changed by DTMF codes sent by a telephone connected to the **Telephone** port or the **Fax/Modem/Phone** port. The configuration by DTMF is limited to those parameters the user may change most likely according to his operation needs.

The inputs always have the following format:

*5	ACCESS	PAR	XXXXXX	#
Command ID	Access code	Parameter no.	Value	Save

- *5 The command prefix informs the device that a configuration setting is to be made.
- ACCESS The Access code (DTMF PASSWORD) protects your configuration against intervention by others. Default: 000000
The command ID and the access code together ensure that accidental incorrect inputs do not change your configuration.
- PAR You use the 3-digit **command ID** to specify which parameter you wish to set.
- XXXXX These digits (max. 6) set the new value for this parameter.
- # This character is the signal that the command ends here.

When entering DTMF tones using a connected analogue telephone correct entries are acknowledged by an Accepted Programming Tone. If the input is incorrect you hear the Non Accepted Programming Tone.

Example: *5 ACCESS 00115#
(sets in *para.ini* in section [DIALING] the parameter CHA_TX_VOICE_LEVEL to 15dB)

The table below shows the parameters that can be configured by DTMF codes. These settings are described in chapter **Configuration**, page 24. The table shows the command ID that is to be entered when using the telephone in order to set the according parameter value. The table shows also the section and the name of the parameters so that you can change the parameter settings by sending an SMS to the SAGEM RT3000 or by editing the *para.ini* file

Cmd ID	section	parameter	Min value	Max value	unit
001	DIALING	CHA_TX_VOICE_LEVEL	0	20	*(-1)[dB]
002	DIALING	CHA_RX_VOICE_LEVEL	0	20	*(-1)[dB]
003	DIALING	CHB_TX_VOICE_LEVEL	0	20	*(-1)[dB]
004	DIALING	CHB_RX_VOICE_LEVEL	0	20	*(-1)[dB]
005	DIALING	CHA_DIAL_TIMEOUT	10	1200	*10[ms]
006	DIALING	CHB_DIAL_TIMEOUT	10	1200	*10[ms]
007	MOBILE_CONFIG	CLIR	0	1	NO/YES
008	MOBILE_CONFIG	SIMPIN	0000	99999999	
009	CALL_MUX	VOICE_ALERT	1	4	A,B,AB
010	CALL_MUX	DATA_ALERT	1	4	A,B,C,AB
011	CALL_MUX	FAX_ALERT	1	4	A,B,C,AB
012	CALL_MUX	FAX_PORT_B	0	1	NO/YES
013	CALL_MUX	FAX_REPORT_ON_SUCCESS	0	1	NO/YES
014	FLASH	CHA_FLASH_MIN	7	55	*10[ms]
015	FLASH	CHA_FLASH_MAX	12	65	*10[ms]
016	FLASH	CHB_FLASH_MIN	7	55	*10[ms]
017	FLASH	CHB_FLASH_MAX	12	65	*10[ms]
018	DEVICE_ACCESS	SMS_CONFIG	0	1	NO/YES
019	DEVICE_ACCESS	SMS_PORT	1	3	P1/P2
020		SYSTEM_TIME	0	235959	hh:mm:ss
021	MOBILE_CONFIG	SIMPIN	0	0	DELETE
022	MOBILE_CONFIG	SIMSTATE	0	0	DELETE
023	DEVICE_ACCESS	DTMF_PASSWORD	000000	999999	
024	PSTN_SMS	PSTN_SMS_CENTER	Phone number		Number
025	PSTN_SMS	ERROR_REPORT	0	1	NO/YES
026	PSTN_SMS	LOCAL_NUMBER	Phone number		Number
027	PSTN_SMS	SMS_PROTOCOL	1	2	Protocol

15.2 Remote configuration by SMS

You may change the file *para.ini* with a configuration SMS. You have to send an SMS to the SAGEM RT3000 from a remote location. You can configure up to 5 remote stations that are allowed to send a configuration SMS (see *Settings for the configuration access via SMS and FTP*, page 87).

- The character “_” occurring in section names has to be replaced by space character.
Example: #5000000CALL MUX,VOICE ALERT,B#

The SMS has to be in the following format:

#5 0000000 SECTION,PARA,XX #

- #5** The command prefix informs the device that a configuration setting is to be made.
- 0000000** The DEVICE PASSWORT protects your configuration against intervention by others.
 The command prefix and the access code together ensure that accidental incorrect inputs do not change your configuration.
- SECTION** this specifies the section of the *para.ini* to which the parameter belongs to.
 (_ occurring in section names has to be replaced by space character.)
- ,** separator
- PARA** this specifies the parameter of the *para.ini* you wish to set.
 (_ occurring in parameter names has to be replaced by space character)
- ,** separator
- XX** These 2 characters or digits (alphanumeric) set the new value for this parameter.
- #** This character is the signal that the command ends here.

- The section and parameter you want to change have to exist in the *para.ini* file.
- Configuration by SMS is only possible if in the section [DEVICE_ACCESS] the parameter SMS_CONFIG=YES is set (Default).
- If SMS_CLIP=YES is set, the telephone numbers of the stations that are allowed to send a configuration SMS have to be set in the section [DEVICE_ACCESS] as parameter SERVICE_CLIP_0 to SERVICE_CLIP_4.
- The SIMPIN and the parameter SMS_CONFIG cannot be modified by an SMS.

15.3 Configuration by FTP (Local and Remote)

The configuration of the SAGEM RT3000 is written in the file *para.ini* that is stored in the memory of the device. You can edit this file with a text editor (capable of writing plain text).

To do this do the following steps:

To edit the configuration file *para.ini*:

1. Download by FTP
 2. Edit
 3. Upload by FTP
1. Download the file *para.ini* from the SAGEM RT3000 to your computer using a FTP program. (FTP programs are available in the Internet as freeware.)

You can download the *para.ini* file

 - from a local PC that is connected to the SAGEM RT3000 via its RS-232 port or its USB port
 - from a remote PC that can establish a PPP connection via CSD (Circuit Switched Data) connection to the SAGEM RT3000.

You can configure up to 5 remote stations that are allowed to download and upload files (see *Settings for the configuration access via SMS and FTP*, page 87).

To establish the connection to the SAGEM RT3000 with a Windows computer you have to establish and start

1. the DIAL UP NETWORK connection to the SAGEM RT3000 (see connection data below) and
2. establish the FTP connection to the SAGEM RT3000 (see connection data below).

Download from:

Local PC:

Dial Up Network:

Dial string: ***98#**
User name: **service**
Password: **service**
Use the modem driver that belongs to the SAGEM RT3000: Rt3000

FTP program:

IP number: **192.168.0.8**
User name: **service**
Password: **service**

User name and password are stored in the *para.ini* file.

Default settings are:

[SERVICE_IF]
USER=service
PASSWORD=service

Download from: **Remote PC:**

Make a CSD (Circuit Switched Data) connection - that means normal dial-up connection - to the SAGEM RT3000.

Dial Up Network:

Dial string: **Telephone number (Data)**

User name: **service**

Password: **service**

FTP program:

IP number: **192.168.0.8**

User name: **service**

Password: **service**

2. Edit the file *para.ini* with a text editor (plain text!). See *Parameters in the file para.ini: advanced configuration*, page 86.
3. Upload the *para.ini* file using the FTP program.
Use the same connection as for downloading.

- ☞ For service connections from remote computers the telephone numbers of those stations have to be set in the *para.ini* and the calls have to signal their own telephone numbers (CLIR deactivated). So the SAGEM RT3000 can check if the calling station is allowed to configure by comparing the signalled telephone number with the numbers in the *para.ini*.

(see *Settings for the configuration access via SMS and FTP*, page 87)

Example:

[REMOTE_ACCESS]

SERVICE_CLIP_4=+4940553045830

Telephone
number



16 Parameters in the file para.ini: advanced configuration

The following parameters can be set

- by a SMS from a remote location [by SMS] or
- by editing the file *para.ini* that can be downloaded using an FTP program [by FTP] or
- by entering DTMF codes (using a telephone set) [by DTMF] or
- by entering AT commands (see *AT Command Interface*, page 70) [by AT commands]

So under the heading of the following chapters this is mentioned using the terms "by SMS", "by FTP", "by DTMF" or "by AT commands".

16.1 Settings for configuration access via DTMF

To configure the SAGEM RT3000 locally by sending DTMF codes from a connected telephone you need to enter an Access code. This Access code is stored in the parameter file and can be changed.

Section: DEVICE_ACCESS			
Meaning	Parameter	Permitted Values	Factory Setting
Access code for DTMF configuration	DTMF_PASSWORD	000000 to 999999	000000

16.2 Settings for the configuration access via SMS and FTP

The SAGEM RT3000 must know the remote stations that should be allowed to do remote service or configuration calls by FTP. For SMS remote configuration you can configure if the CLIP is checked or not. You can configure up to 5 stations for SMS and FTP access each. SMS access must also be allowed by setting the parameter SMS_CONFIG=YES.

Section: DEVICE_ACCESS			
Meaning	Parameter	Permitted Values	Factory Setting
Activate SMS config	SMS_CONFIG	YES, NO	YES
PWD for config SMS	DEVICE_PASSWORD	000000 to 999999	000000
Activate CLIP check	SMS_CLIP=YES	YES, NO	YES
CLIP for Remote SMS	SERVICE_CLIP_0	100 digits	
CLIP for Remote SMS	SERVICE_CLIP_1	100 digits	
CLIP for Remote SMS	SERVICE_CLIP_2	100 digits	
CLIP for Remote SMS	SERVICE_CLIP_3	100 digits	
CLIP for Remote SMS	SERVICE_CLIP_4	100 digits	

Section: REMOTE_ACCESS			
Meaning	Parameter	Permitted Values	Factory Setting
CLIP for Remote CSD	SERVICE_CLIP_0	100 digits	
CLIP for Remote CSD	SERVICE_CLIP_1	100 digits	
CLIP for Remote CSD	SERVICE_CLIP_2	100 digits	
CLIP for Remote CSD	SERVICE_CLIP_3	100 digits	
CLIP for Remote CSD	SERVICE_CLIP_4	100 digits	

Section: SERVICE_IF			
Meaning	Parameter	Permitted Values	Factory Setting
See 15.3	USER	100 chars	service
See 15.3	PASSWORD	100 chars	service

16.3 Power-missing SMS

Can be configured by SMS (see page 83)
Can be configured by FTP (see page 84)

If the mains power fails, the SAGEM RT3000 can send an SMS to a GSM telephone number, which has to be pre-configured in the parameter file.

The function is activated by

[DEVICE_ACCESS]

POWER_REPORT=YES

POWER_REPORT_NR=<<SMS Phone Number for Power Report>

Section: DEVICE_ACCESS			
Meaning	Parameter	Permitted Values	Factory Setting
Activate power report	POWER_REPORT	YES, NO	NO
Telephone number for sending power report to	POWER_REPORT_NR	100 digits	

16.4 Select Port for Incoming SMS

Can be configured by SMS (see page 83)
Can be configured by FTP (see page 84)
Can be configured by DTMF (see page 81)

You can select where an incoming SMS should be routed to.

Section: DEVICE_ACCESS	
SMS_PORT=A	to the Telephone port (Landline SMS capable telephone set required)
SMS_PORT=B	to the Telephone port (Landline SMS capable telephone set required)
SMS_PORT=C	to the PC interface (Default)

Section: DEVICE_ACCESS			
Meaning	Parameter	Permitted Values	Factory Setting
Switch incoming SMS to PC-SMS or to analogue SMS	SMS_PORT	A, B, C	C

16.5 Select Baudrate for Debug-RS232

Can be configured by SMS (see page 83)

Can be configured by FTP (see page 84)

The baudrate of the Debug-Interface can be configured. The Debug-Interface is not part of a standard product.

[SERVICE_IF]

BAUDRATE=57600

Section: SERVICE_IF			
Meaning	Parameter	Permitted Values	Factory Setting
Baudrate for debug RS232	BAUDRATE	300, 600, 1200, 2400, 4800, 9600, 19200, 38400, 57600, 115200	57600

16.6 Pre-Selection

Can be configured by SMS (see page 83)

Can be configured by FTP (see page 84)

Section: PRESELECT_HUNGARY			
This section contain the special parameter for the pre-selection mode.			
Activate Fixed NW pre-selection	PRESELECT	YES,NO	YES
	NAT_CARRIER	00 to 99	00
	INTERNAT_CARRIER	00 to 99	00
	KS_EX_0	00 to 99	-
	KS_EX_1	00 to 99	40
	KS_EX_2	00 to 99	41
	KS_EX_3	00 to 99	50
	KS_EX_4	00 to 99	51
	KS_EX_5	00 to 99	71
	KS_EX_6	00 to 99	80
	KS_EX_7	00 to 99	81
	KS_EX_8	00 to 99	90
	KS_EX_9	00 to 99	91
	KS_EX_10... KS_EX_24	00 to 99	undefined

16.7 Prefix for International calls

Can be configured by SMS (see page 83)
Can be configured by FTP (see page 84)

In GSM networks the “+” character is the common prefix for international calls. In landline networks it is usually the “00”. Some countries are using different digits.

You can select with the parameter [INTERNATIONAL], which two digit prefix should be converted into the “+” prefix.

Section: CALL_MUX			
Meaning	Parameter	Permitted Values	Factory Setting
Conversion to +	INTERNATIONAL	00 to 99	00

16.8 Prefix for Analogue Data and Fax calls

Can be configured by SMS (see page 83)
Can be configured by FTP (see page 84)

If your Analogue modem or fax machine dials either the fax or data prefix before the telephone number, the RT3000 detects that it is an Analogue data or fax call and switches in the correct mode. You can change these prefixes. Please ensure that your chosen prefix differs from all DTMF configuration code.

Section: DIALING			
Meaning	Parameter	Permitted Values	Factory Setting
Force Analogue data call	DATA_PREFIX	Dial string of 3...6 characters	***
Force Analogue fax call	FAX_PREFIX	Dial string of 3...6 characters	###

16.9 Local accepted emergency number

Can be configured by SMS (see page 83)
Can be configured by FTP (see page 84)

The GSM standard does only allow a few Emergency call numbers. You may specify up to 3 Emergency numbers, which will be translated into a GSM-valid Emergency number automatically, if it is entered at the **Phone** or **Fax/Modem/Phone** port. The local accepted emergency numbers specified with EMERGENCY_1 und EMERGENCY_3 will be translated to the GSM-valid emergency number 112, the local emergency number specified with parameter EMERGENCY_2 will be translated to the GSM-valid emergency number 911.

Example:

You have specified 111111 as the SAGEM RT3000 Emergency number. If this number is dialled, the SAGEM RT3000 will translate this number to an official GSM-valid emergency number.

Section: CALL_MUX			
This section includes mainly the parameter for call routing			
Meaning	Parameter	Permitted Values	Factory Setting*
Local accepted emergency number	EMERGENCY_1	40 digits	112
Local accepted emergency number	EMERGENCY_2	40 digits	-
Local accepted emergency number	EMERGENCY_3	40 digits	-

* depending on country and/or product version

16.10 Port Allocation

Can be configured by SMS (see page 83) Can be configured by FTP (see page 84) Can be configured by DTMF (see page 81)

You may specify to which port incoming calls will be routed to. Incoming calls will be routed depending on the bearer capability to distinguish between voice, data, fax and in accordance to your configuration.

Example:

Section: CALL_MUX	
VOICE_ALERT=AB	Voice calls will be routed to the Telephone Port and the Fax/Modem/Phone Port
DATA_ALERT=B	Data calls will be routed to the Fax/Modem/Phone
FAX_ALERT=B	Fax calls will be routed to the Fax/Modem/Phone

A = Phone port

B = Fax/Modem/Phone port

C = PC-Port

16.11 Analogue Fax Configuration

Section: CALL_MUX			
Meaning	Parameter	Permitted Values	Factory Setting
Fax only on Port B (no voice)	FAX_PORT_B	YES, NO	NO
Timeout for local fax in seconds	FAX_ACCEPT_TIMEOUT	5 to 99999	20
Maximum retries for local fax	FAX_RETRY_MAX	0 to 99999	3
Delay between retries in seconds	FAX_RETRY_DELAY	1 to 99999	30
Success fax after completed MOC	FAX_SUCCESS_REPORT	YES, NO	NO

Section: FAX			
Meaning	Parameter	Permitted Values	Factory Setting
Fax Identification (if remote identification is not available, yet)	IDENT	20 chars	RT3000

Descriptions:

Fax only on Port B (no voice)

[Can be configured by DTMF, SMS, FTP] In case of any trouble with the recognition of outgoing fax sent from the fax machine connected to the SAGEM RT3000, you can configure that each call initiated on the **Fax/Modem/Phone** will be handled like a fax call. Therefore set this parameter:

FAX_PORT_B=YES.

Timeout for local fax in seconds

[Can be configured by SMS, FTP] You can configure in what time (in seconds) the fax machine connected to the SAGEM RT3000 must react to an incoming fax call to accept the call. If the timeout expires, the SAGEM RT3000 will not receive the incoming fax.

FAX_ACCEPT_TIMEOUT=20

Maximum retries for local fax

[Can be configured by SMS, FTP] If the SAGEM RT3000 has stored a part of a received fax because the connection to the local fax has been interrupted, the SAGEM RT3000 will try to resend the stored part of the fax document to the local fax machine automatically.

With the parameter FAX_RETRY_MAX=<> you can configure the number of retries.

With the parameter FAX_RETRY_DELAY=<> you can configure the delay between two retries.

Success fax after completed MOC

[Can be configured by DTMF, SMS, FTP] When you send a fax by your local fax machine via the SAGEM RT3000 the SAGEM RT3000 can return a report, whenever the transmission to the remote station is successful. Parameter:

FAX_SUCCESS_REPORT= YES

Fax Identification

[Can be configured by SMS, FTP] When you send a fax by your local fax machine via the SAGEM RT3000 to a remote station, your local fax machine will show the Fax Identification configured in this parameter. This is necessary because of the special mechanism required to transmit the fax via the GSM network. When receiving a fax with the local fax machine, the identification of the remote fax machine will be shown.

IDENT=<RT3000>

16.12 Billing Tone configuration

Can be configured by SMS (see page 83)
Can be configured by FTP (see page 84)

The SAGEM RT3000 can generate billing pulses on the **Telephone** port and on the **Fax/Modem/Phone** port.

Enable/Disable

This feature can be activated or deactivated for both ports separately [CHA_BILLING_ENABLED, CHB_BILLING_ENABLED].

Text Pulse Frequency

The RT3000 can generate billing pulses with a frequency of 12kHz [CHx_16KHZ_BURST=No], or 16kHz [CHx_16KHZ_BURST=Yes].

Tax-pulse cadence

The duration of the tax-pulse can be selected with this parameter:
CHx_PULSE_DURATION
CHx_PULSE_DELAY

tax-pulse level

The tax-pulse signal level can be adjusted with the following parameter:

CHA_PULSE_LEVEL

e.g.: CHA_PULSE_LEVEL=2,5.

Section: BILLING			
Meaning	Parameter	Permitted Values	Factory Setting
Enable Billing Port A	CHA_BILLING_ENABLED	YES, NO	NO
the tax-pulse duration in x*10ms	CHA_PULSE_DURATION	1 to 100	20
the tax-pulse delay in x*10ms	CHA_PULSE_DELAY	1 to 60000	100
the tax-pulse level in range from 0-2,5V	CHA_PULSE_LEVEL	0 to 2,5	1
the tax-pulse-frequency, yes to use 16khz, no for 12khz	CHA_16KHZ_BURST	YES,NO	YES
Enable Billing Port B	CHB_BILLING_ENABLED	YES,NO	YES
the tax-pulse duration in x*10ms	CHB_PULSE_DURATION	1 to 100	20
the tax-pulse delay in x*10ms	CHB_PULSE_DELAY	1 to 60000	100
the tax-pulse level in range from 0-2,5V	CHB_PULSE_LEVEL	0 to 2,5	1
the tax-pulse-frequency, yes to use 16khz, no for 12khz	CHB_16KHZ_BURST	YES,NO	NO

16.13 CLIP function configuration

Can be configured by SMS (see page 83)
 Can be configured by FTP (see page 84)
 Can be configured by DTMF (see page 81)

When a call comes in and it is ringing the SAGEM RT3000 can transmit the telephone number of the calling party to the equipment connected to the **Telephone** port or the **Fax/Modem/Phone** port. This function is called CLIP - Calling Line Identification Presentation.

CHx_CLIP_ENABLED	= Yes	Enables the transmission of the CLIP on port x (x=A, B)
	= No	Disables the transmission of the CLIP on port x (x=A, B)

Section: CLIP			
This section includes the parameters for the CLIP function			
Meaning	Parameter	Permitted Values	Factory Setting
Display CLIP Port A	CHA_CLIP_ENABLED	YES, NO	YES
define the delay between end of first ring and start of CID (10ms)	CHA_RING_CLIP_DELAY	50 to 200	50
the amount of seizure bits	CHA_SEIZURE_BITS	96 to 300	300
the amount of mark bits	CHA_MARK_BITS	60 to 205	180
Display CLIP Port B	CHB_CLIP_ENABLED	YES, NO	YES
define the delay between end of first ring and start of CID (10ms)	CHB_RING_CLIP_DELAY	50 to 200	50
the amount of seizure bits	CHB_SEIZURE_BITS	96 to 300	300
the amount of mark bits	CHB_MARK_BITS	60 to 205	180

16.14 Configuration of the Flash signal

Can be configured by SMS (see page 83)
 Can be configured by FTP (see page 84)
 Can be configured by DTMF (see page 81)

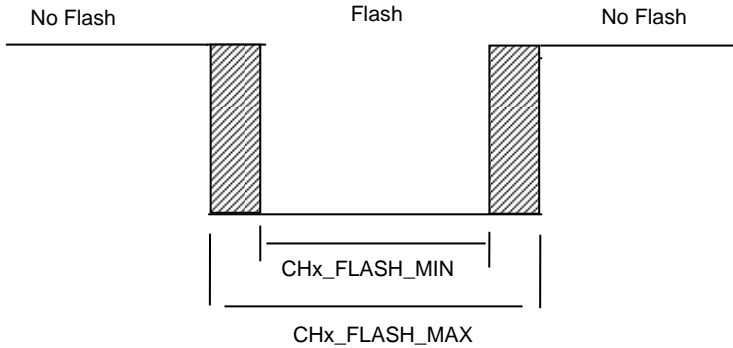

Section: FLASH			
Meaning	Parameter	Permitted Values	Factory Setting
The minimum flash duration. Shorter pulses will be interpreted as parts of pulse-dial! (10ms)	CHA_FLASH_MIN	4 - 55	7
The maximum flash duration. Longer pulses will be interpreted an onhook/offhook! (10ms)	CHA_FLASH_MAX	12 - 65	50
The minimum flash duration. Shorter pulses will be interpreted as parts of pulse-dial! (10ms)	CHB_FLASH_MIN	4 - 55	7
The maximum flash duration. Longer pulses will be interpreted an onhook/offhook! (10ms)	CHB_FLASH_MAX	12 - 65	50

16.15 RING frequency

Can be configured by SMS (see page 83)

Can be configured by FTP (see page 84)

The frequency of the RING signal can be selected between 25Hz and 50Hz.

CHA_HIGH_RING_FREQ defines the RING frequency for the Telephone port.

CHB_HIGH_RING_FREQ defines the RING frequency for the Fax/Modem/Phone port.

If the setting is NO, the RING frequency is 25Hz.

Section: RING			
Meaning	Parameter	Permitted Values	Factory Setting
Ring 50Hz (else 25Hz)	CHA_HIGH_RING_FREQ	YES, NO	NO
Ring 50Hz (else 25Hz)	CHB_HIGH_RING_FREQ	YES, NO	NO

16.16 Dialling configuration

Can be configured by SMS (see page 83)

Can be configured by FTP (see page 84)

Fast Dialling

Normally you must enter the telephone number completely before the SAGEM RT3000 can start dialling. The SAGEM RT3000 starts dialling until you do not press any more key on the telephone and after the *dial timeout* is expired - the duration the SAGEM RT3000 waits for any new key stroke.

If the function *Fast Dialling* is enabled, the SAGEM RT3000 starts dialling immediately when you terminate the dial sequence by pressing the *Fast Dialling Key*: a **#**.

For example: 00331234567#.

Section: DIALING			
Meaning	Parameter	Permitted Values	Factory Setting
Fast Dialling Port A	CHA_FAST_DIAL	YES, NO	NO
Dial timeout in 10ms	CHA_DIAL_TIMEOUT		600
Fast Dialling Port B	CHB_FAST_DIAL	YES, NO	NO
Dial timeout in 10ms	CHB_DIAL_TIMEOUT		600

16.17 Call Wait Tone On/Off

Can be configured by SMS (see page 83)
 Can be configured by FTP (see page 84)
 Can be configured by DTMF (see page 81)

Calls that come in during an active connection can be signalled by the Call Wait Signal. This function can be switched on or off for both ports separately.

When activated this function can only take effect when it is supported by the network and your subscription.

Section: DIALING			
Meaning	Parameter	Permitted Values	Factory Setting
CallWait tone generated on port A	CHA_LOCAL_CALL_WAIT	YES, NO	NO
CallWait tone generated on port B	CHB_LOCAL_CALL_WAIT	YES, NO	NO

16.18 Local Ringback tone on/off

Can be configured by SMS (see page 83)
 Can be configured by FTP (see page 84)

The Ringback tone is the tone you can hear when making a call after you have dialled the telephone number and when the called remote station is ringing. By default this tone will be generated by the network. If you want that the Ringback tone is generated by the SAGEM RT3000 set the following parameter to YES:

CHx_LOCAL_CALL_CTRL=YES.

Section: DIALING			
Meaning	Parameter	Permitted Values	Factory Setting
Local RingBack generated	CHA_LOCAL_CALL_CTRL	YES, NO	NO
Local RingBack generated	CHB_LOCAL_CALL_CTRL	YES, NO	NO

16.19 Voice signal volume on Telephone and Fax/Modem/Phone port

Can be configured by SMS (see page 83)
 Can be configured by FTP (see page 84)
 Can be configured by DTMF (see page 81)

You can adjust the voice signal volume on the **Telephone** and **Fax/Modem/Phone** port by modifying the following parameters. If you set the parameter value to "0" you get the loudest signal.

CHx_TX_VOICE_LEVEL (Signal directed to the remote station)

CHx_RX_VOICE_LEVEL (Signal directed to your local equipment)

You can set the parameter for both ports separately.

Section: DIALING			
Meaning	Parameter	Permitted Values	Factory Setting
Tx Level *(-1)[dB] on port A	CHA_TX_VOICE_LEVEL	0 down to -20	-7
Rx Level *(-1)[dB] on port A	CHA_RX_VOICE_LEVEL	0 down to -20	-7
Tx Level *(-1)[dB] on port B	CHB_TX_VOICE_LEVEL	0 down to -20	-7
Rx Level *(-1)[dB] on port B	CHB_RX_VOICE_LEVEL	0 down to -20	-7

16.20 Telephone and Fax/Modem/Phone port impedance

Can be configured by SMS (see page 83)
 Can be configured by FTP (see page 84)

You can adjust the input impedance of the **Telephone** and **Fax/Modem/Phone** port separately. You can select 600R, 900R or a complex matching.

Section: DIALING			
Parameter	Permitted Values	Factory Setting	
Input Impedance Port A	CHA_INPUT_IMPEDANCE	REAL600, REAL900, COMPLEX	COMPLEX
Input Impedance Port B	CHB_INPUT_IMPEDANCE	REAL600, REAL900, COMPLEX	COMPLEX

16.21 GPRS Configuration

Can be configured by SMS (see page 83)
 Can be configured by FTP (see page 84)
 Can be configured by AT-command (see p. 63)

To set-up GPRS connections, the PDP_CONTEXT for this connection must be specified in the *para.ini* file. For each GPRS provider an own section has to be created in the parameter file. For some GPRS providers the configuration is already pre-configured:

```
[T-D1]
PDP_CONTEXT=1,"IP","internet.t-d1.de","0.0.0.0",0,0
[D2]
PDP_CONTEXT=1,"IP","volume.d2gprs.de","0.0.0.0",0,0
[EPLUS]
PDP_CONTEXT=1,"IP","internet.eplus.de","0.0.0.0",0,0
[VIAG]
PDP_CONTEXT=1,"IP","internet","0.0.0.0",0,0
```

You can add a new GPRS provider by creating an own section for it:

```
[NEW-PROVIDER]
PDP_CONTEXT=<values for the new-Provider>
```

It is possible to add several of new providers by adding a corresponding number to the new sections.

In the section [GPRS-CONFIG] you select the active provider:

```
[GPRS-CONFIG]
PROVIDER=NEW-PROVIDER
```

If you enter the APN by the AT command AT+CGDCONT=<PDP_CONTEXT>, this will overwrite the parameter value of PROVIDER to AT_PARSER.

Section: GPRS_CONFIG			
Meaning	Parameter	Permitted Values	Factory Setting
Provider section name (predefined and new)	PROVIDER	existing section name (e.g.: T-D1)	
Reserved	SPECIAL_CGATT=NO		

Section: <Provider>			
Meaning	Provider name	Parameter	Factory Setting
Predefined Provider	T-D1	PDP_CONTEXT	1,"IP","internet.t-d1.de","0.0.0.0",0,0
Predefined Provider	D2	PDP_CONTEXT	1,"IP","volume.d2gprs.de","0.0.0.0",0,0
Predefined Provider	EPLUS	PDP_CONTEXT	1,"IP","internet.eplus.de","0.0.0.0",0,0
Predefined Provider	VIAG	PDP_CONTEXT	1,"IP","internet","0.0.0.0",0,0
New Provider	i.e. myGPRS	PDP_CONTEXT	PDP context as given by the new provider.

16.22 CLIR on/off

Can be configured by SMS (see page 83)
 Can be configured by FTP (see page 84)
 Can be configured by DTMF (see page 81)

When you make a call your telephone number will be presented to the remote party when this function is supported by the network. You can disable this function by setting the following parameter:

CLIR=NO.

Section: MOBILE_CONFIG			
Meaning	Parameter	Permitted Values	Factory Setting
Enable CLIR	CLIR	YES, NO	YES

16.23 PIN number

Can be configured by SMS (see page 83)
 Can be configured by FTP (see page 84)
 Can be configured by DTMF (see page 81)

The PIN number is stored in the parameter SIMPIN=<Pinnumber>.

Section: MOBILE_CONFIG			
Meaning	Parameter	Permitted Values	Factory Setting
SIM PIN	SIMPIN		empty

16.24 AT command parameter

Can be configured by AT-command (see p. 63)

The settings you enter by AT commands are stored in the configuration file *para.ini* in an own section.

This section is reserved.

16.25 Polarity reversal (Spain)

Can be configured by SMS (see page 83)
Can be configured by FTP (see page 84)

This function simulates the Polarity reversal feature provided on the Spanish fixed telephone network, but there are some differences, caused by the adaptation to the wireless environment.

Section: DIALLING			
Meaning	Parameter	Permitted Values	Factory Setting
Polarity reversal on/off on port A	CHA_POLARITY_REV	YES,NO	NO
Polarity reversal on/off on port B	CHB_POLARITY_REV	YES,NO	NO

16.26 Hang-up delay

Can be configured by SMS (see page 83)
Can be configured by FTP (see page 84)

This function allows, in case of an incoming call to answer the call, to hang-up the call and to continue the call, if you pick-up the phone again within the selected delay, if the remote party has not yet terminate the call. This function is always active, if the Polarity reversal has been activated. If the Polarity reversal function is off you may activate the Hang-up delay by parameter.

Section: DIALLING			
Meaning	Parameter	Permitted Values	Factory Setting
Hang-up delay on/off port A	CHA_MTC_HOOK_DELAY	YES, NO	NO
Hang-up delay port A	CHA_MTC_HOOK_TIMEOUT	0....30000	6000 = 1min
Hang-up delay on/off port B	CHB_MTC_HOOK_DELAY	YES, NO	NO
Hang-up delay port B	CHB_MTC_HOOK_TIMEOUT	0....30000	6000 = 1min

16.27 MNP Flow Control

Can be configured by SMS (see page 83)

Can be configured by FTP (see page 84)

The Microcom Networking Protocol MNP is used for error correction and flow control on the link to the local connected Modem. If you want MNP active set the following parameter as follows: MNP=YES.

Section: MODEM			
Meaning	Parameter	Permitted Values	Factory Setting
MNP setting	MNP	YES,NO	YES (NO in Spain)

16.28 Maximum local modem speed

Can be configured by SMS (see page 83)

Can be configured by FTP (see page 84)

This parameter sets the initial baudrate for the negotiation.

Section: MODEM			
Meaning	Parameter	Permitted Values	Factory Setting
max. local speed	MAX_SPEED	300, 1200, 2400, 4800, 9600, 14400	9600

16.29 Minimum local modem speed

Can be configured by SMS (see page 83)

Can be configured by FTP (see page 84)

This parameter sets the lowest speed accepted during baudrate negotiation.

Section: MODEM			
Meaning	Parameter	Permitted Values	Factory Setting
min. local speed	MIN_SPEED	300, 1200, 2400, 4800, 9600, 14400	300

16.30 GSM speed

Can be configured by SMS (see page 83)
Can be configured by FTP (see page 84)

This parameter sets the baudrate used on GSM to connect to remote modem. (Depends on the network and your subscription.)

Section: MODEM			
Meaning	Parameter	Permitted Values	Factory Setting
GSM and remote modem baudrate	GSM_SPEED	2400, 4800, 9600	automatic

16.31 Early connect of local Modem

Can be configured by SMS (see page 83)
Can be configured by FTP (see page 84)

If this parameter is set, the local modem starts to negotiate at the configured time, independent of a GSM connect.

Section: MODEM			
Meaning	Parameter	Permitted Values	Factory Setting
Time between dialing and start of negotiation (local connection before GSM connection)	EARLY_START_LOCAL	0 to 60	Parameter not active Local connection setup starts when GSM connection is established.

16.32 Data numbers

Can be configured by SMS (see page 83)
Can be configured by FTP (see page 84)

These parameters force data calls for special numbers on outgoing calls (for modems without correct calling tone)

Section: MODEM			
Meaning	Parameter	Permitted Values	Factory Setting
This number forces a data call	DATA_NUM_1 DATA_NUM_2 DATA_NUM_3	Number (max 30 digits)	-

16.33 GSM baudrate depending on dialled number (number)

Can be configured by SMS (see page 83)

Can be configured by FTP (see page 84)

This parameters defines the number which for the baudrate is set with SPEED_FOR_NUM.

If this number is dialled the selected GSM speed is set.

Section: SPECIAL_MODEM			
Meaning	Parameter	Permitted Values	Factory Setting
This number forces the baudrate for GSM as set in SPEED_FOR_NUM	SPEED_NUM	Number (max 30 digits)	-
This number forces the baudrate for GSM as set in SPEED_FOR_NUM_2	SPEED_NUM_2	Number (max 30 digits)	-
This number forces the baudrate for GSM as set in SPEED_FOR_NUM_3	SPEED_NUM_3	Number (max 30 digits)	-

16.34 GSM baudrate depending on dialled number (baudrate)

Can be configured by SMS (see page 83)

Can be configured by FTP (see page 84)

This parameters set the GSM speed for a special number

Section: SPECIAL_MODEM			
Meaning	Parameter	Permitted Values	Factory Setting
This number forces a data call	SPEED_FOR_NUM	2400, 4800, 9600	-
This number forces a data call	SPEED_FOR_NUM_2	2400, 4800, 9600	-
This number forces a data call	SPEED_FOR_NUM_3	2400, 4800, 9600	-

16.35 Fixed Network SMS

Can be configured by SMS (see page 83)
 Can be configured by FTP (see page 84)

Section: PSTN_SMS			
Meaning	Parameter	Permitted values	Factory Setting
Telephone number of the PSTN-SMS-Center (Can be configured by DTMF (see page 81))	PSTN_SMS_CENTER	Number Max lenght 24 digits	0193010
delivery mode	DELIVERY_MODE	0 only reserved for future	0
timeout for waiting on offhook after ringing	RING_TIMEOUT	5 second to 10 minutes in 10 ms steps	600
Time between delivery tries	DELIVERY_DELAY	5 second to 10 minutes in 10 ms steps	3000
Ignore SMSC Header	SMSC_HEADER	YES,NO	NU_FALSE
Error report if sent SMS can not be delivered	ERROR_REPORT	YES,NO	YES
Protocol parameter	ACK_INFO	Reserved	Reserved
Protocol parameter	ACK_PAYLOAD	Reserved	Reserved
Protocol parameter	ALL_MSG_AT_ONCE	Reserved	Reserved
Telephone number of the PSTN-SMS-Center for RX (Can be configured by DTMF (see page 81))	LOCAL_NUMBER	Phone number	

16.36 Frequency band selection GSM 900, DCS 1800, PCS 1900

Can be configured by SMS (see page 83)

Can be configured by FTP (see page 84)

Section: MOBILE_CONFIG			
Meaning	Parameter	Permitted values	Factory Setting
Selects the GSM frequency band	BAND	GSM DCS PCS DUAL_EU DUAL_US ALL TRI GSM850 GSM850_1900	ALL

Setting	Meaning	 <p>Do not change the factory setting in the para.ini!</p> <p>The RT3000 with 900/1800 MHz antenna should only be used in 900 MHz or 1800 MHz networks.</p> <p>The RT3000 with 1900 MHz antenna should only be used in 1900 MHz networks.</p> <p>The RT3000 with a 850/1900 MHz antenna should only be used in 850 MHz or 1900 MHz networks.</p> <p>If you do not know the frequency band you are using, please contact your GSM network operator.</p>
GSM	900 MHz only	
DCS	1800 MHz only	
PCS	1900 MHz only	
DUAL_EU	Autoselect 900/1800 MHz	
DUAL_US	Autoselect 900/1900 MHz	
ALL	Autoselect 900/1800/1900 MHz (RT3000 with MO190) Autoselect 850/900/1800/1900 MHz (RT3000 with MO200)	
TRI	900/1800/1900 MHz	
GSM850	850 MHz (RT3000 with MO200)	
GSM850_1900	850/1900 MHz (RT3000 with MO200)	

16.37 Identification

Section: GENERAL		
Meaning	Parameter	Setting
Reserved	PRODUCT_CODE	DNT8115
Reserved	VERSION_PARA_INI	1.026

16.38 Hotline Service

Can be configured by SMS (see page 83)

Can be configured by FTP (see page 84)

Section: HOTLINE		
Meaning	Parameter	Setting
Hotline service active / not active	ACTIVE	NO, YES
Phone number for hotline service	NUMBER	Phone number
Time until dialling	TIME	5 ... 60 5 = 5 sec 60 = 60 sec

16.39 Sample File

;RT-XNG Parameter File

[SERVICE_IF]

USER=service

PASSWORD=service

BAUDRATE=57600

[PRESELECT_HUNGARY]

PRESELECT=NO

NAT_CARRIER=00

INTERNAT_CARRIER=00

KS_EX_0=

KS_EX_1=40

KS_EX_2=41

KS_EX_3=50

KS_EX_4=51

KS_EX_5=71

KS_EX_6=80

KS_EX_7=81

KS_EX_8=90

KS_EX_9=91

; up to KS_EX_24

[REMOTE_ACCESS]

SERVICE_CLIP_0=-

SERVICE_CLIP_1=-

SERVICE_CLIP_2=-

SERVICE_CLIP_3=-

SERVICE_CLIP_4=-

; SMS / DTMF

[DEVICE_ACCESS]

DEVICE_PASSWORD=000000

DTMF_PASSWORD=000000

SERVICE_CLIP_0=

SERVICE_CLIP_1=

SERVICE_CLIP_2=

SERVICE_CLIP_3=

SERVICE_CLIP_4=

; POWER_REPORT: YES or NO, default is YES

Parameters in the file para.ini: advanced configuration

```
POWER_REPORT=NO
POWER_REPORT_NR=
SMS_PORT=C
; SMS_CONFIG: YES or NO, default is YES
SMS_CONFIG=YES
; SMS_CLIP: YES or NO, default is NO
SMS_CLIP=YES
; TEST_SMS: only used to test configuration-sms
TEST_SMS=222

[CALL_MUX]
VOICE_ALERT=A
; can be A, B, AB or BA - default A
DATA_ALERT=B
; C = PC-PORT; can be A, B, C, AB, etc
FAX_ALERT=B
; can be ABC, default is B
FAX_PORT_B=NO
; if YES, Port B generates only fax calls
DATA_PORT_B=NO
; YES makes port B Data only (FAX_PORT_B=YES overrides)
FAX_ACCEPT_TIMEOUT=20
; time in seconds, to wait for hookoff of local fax
FAX_RETRY_MAX=3
; count of retries to deliver local fax
FAX_RETRY_DELAY=30
; time in seconds, to wait for next retry
INTERNATIONAL=00
FAX_SUCCESS_REPORT=NO
EMERGENCY_1=112
EMERGENCY_2=112
EMERGENCY_3=112
; prefix to force data/fax call (do NOT use DTMF config sequences)
DATA_PREFIX=***
FAX_PREFIX=###

[FAX]
IDENT=RT3000
;FAXAPP_DEBUG=COM
;T30_DEBUG=COM
```

```
[PSTN_SMS]
```

```
SMS_PROTOCOL=1
PSTN_SMS_CENTER=0193010
RING_TIMEOUT=600
DELIVERY_DELAY=3000
ERROR_REPORT=YES
;*** special parameters for protocol 1
DELIVERY_MODE=0
SMSC_HEADER=NO
;pdu-protocol-identifier to default
;SET_DEFAULT_PI=YES
ACK_INFO=YES
;max 20 characters
;ACK_PAYLOAD=
;*** special parameters for protocol 2
;send more than one msg at the same session
ALL_MSG_AT_ONCE=NO
LOCAL_NUMBER=900716800
```

[BILLING]

```
;settings for channel a
CHA_BILLING_ENABLED=NO
CHA_PULSE_DURATION=20
CHA_PULSE_DELAY=100
CHA_PULSE_LEVEL=1
;12kHz and 16kHz. default: 16kHz
CHA_16KHZ_BURST=YES
;settings for channel b
CHB_BILLING_ENABLED=NO
CHB_PULSE_DURATION=20
CHB_PULSE_DELAY=100
CHB_PULSE_LEVEL=1
;12kHz and 16kHz. default: 16kHz
CHB_16KHZ_BURST=YES
```

[CLIP]

```
;settings for channel a
CHA_CLIP_ENABLED=YES
CHA_RING_CLIP_DELAY=50
CHA_SEIZURE_BITS=300
CHA_MARK_BITS=180
;settings for channel b
CHB_CLIP_ENABLED=YES
CHB_RING_CLIP_DELAY=50
```

Parameters in the file para.ini: advanced configuration

```
CHB_SEIZURE_BITS=300
CHB_MARK_BITS=180
```

[FLASH]

```
;settings for channel a
CHA_FLASH_MIN=7
CHA_FLASH_MAX=50
;settings for channel b
CHB_FLASH_MIN=7
CHB_FLASH_MAX=50
```

[RING]

```
;settings for channel a, 25Hz and 50Hz available, default: 25Hz
CHA_HIGH_RING_FREQ=NO
;settings for channel b, 25Hz and 50Hz available, default: 25Hz
CHB_HIGH_RING_FREQ=NO
```

[DIALING]

```
;settings for channel a
;AUTO, REAL600, REAL900, COMPLEX
CHA_INPUT_IMPEDANCE=COMPLEX
CHA_POLARITY_REV=NO
CHA_MTC_HOOK_DELAY=NO
CHA_MTC_HOOK_TIMEOUT=6000
CHA_FAST_DIAL=NO
CHA_DIAL_TIMEOUT=600
CHA_LOCAL_CALL_WAIT=NO
CHA_LOCAL_CALL_CTRL=NO
CHA_TX_VOICE_LEVEL=-7
CHA_RX_VOICE_LEVEL=-7
;settings for channel b
CHB_INPUT_IMPEDANCE=COMPLEX
CHB_POLARITY_REV=NO
CHB_MTC_HOOK_DELAY=NO
CHB_MTC_HOOK_TIMEOUT=6000
CHB_FAST_DIAL=NO
CHB_DIAL_TIMEOUT=600
CHB_LOCAL_CALL_WAIT=NO
CHB_LOCAL_CALL_CTRL=NO
CHB_TX_VOICE_LEVEL=-7
CHB_RX_VOICE_LEVEL=-7
```

[GPRS_CONFIG]

PROVIDER=
SPECIAL_CGATT=NO

[T-D1]

PDP_CONTEXT=1,"IP","internet.t-d1.de","0.0.0.0",0,0

[D2]

PDP_CONTEXT=1,"IP","volume.d2gprs.de","0.0.0.0",0,0

[EPLUS]

PDP_CONTEXT=1,"IP","internet.eplus.de","0.0.0.0",0,0

[VIAG]

PDP_CONTEXT=1,"IP","internet","0.0.0.0",0,0

[AMENA]

PDP_CONTEXT=1,"IP","internet","0.0.0.0",0,0

[MOVISTAR-PLUS]

PDP_CONTEXT=1,"IP","movistar.es","0.0.0.0",0,0

[MOVISTAR-ACTIVA]

PDP_CONTEXT=1,"IP","p.movistar.es","0.0.0.0",0,0

[VODAFONE_SPAIN]

PDP_CONTEXT=1,"IP","airtelnet.es","0.0.0.0",0,0

[MOBILE_CONFIG]

CLIR=YES
BAND=ALL

BEARER_SERVICE=7
SIMPIN=
SIMSTATE=

[GENERAL]

PRODUCT_CODE=DNT8115
VERSION_PARA_INI=1.026
;MOB_DEBUG_TO_LOG=NO

[MODEM]

;; MNP: YES or NO; default YES
MNP=YES

Parameters in the file para.ini: advanced configuration

```
;; max. local speed: 300, 1200, 2400, 4800, 9600, 14400; default 9600
;MAX_SPEED=14400
;; max. local speed: 300, 1200, 2400, 4800, 9600, 14400; default 0 (means
300)
;MIN_SPEED=4800
;; force GSM bearer service on outgoing call: 2400, 4800, 9600; default
automatic
;GSM_SPEED=4800
;; start local modem x seconds after dialing: 0..60; default after GSM
connect
;EARLY_START_LOCAL=0
;; routing of debug output: COM; default off
;DMOD_DEBUG=COM
;DGSM_DEBUG=COM
;MNP_DEBUG=COM
;DP_DEBUG=COM
;; special numbers
DATA_NUM_1=090
DATA_NUM_2=
DATA_NUM_3=

[SPECIAL_MODEM]
; if uncommented: for SPEED_NUM GSM-speed is set as defined in
SPEED_FOR_NUM
;SPEED_NUM=090
;SPEED_FOR_NUM=4800
;SPEED_NUM_2=
;SPEED_FOR_NUM_2=
;SPEED_NUM_3=
;SPEED_FOR_NUM_3=

[AT_PARSER]
ECHO=YES
VERBOSE=YES
QUIET=NO
FLOW_CONTROL=YES
DCD_CONTROL=YES
DTR_CONTROL=YES
ANSWER_RING=0
BAUDRATE=57600
PDP_CONTEXT=1, "IP", "volume.d2gprs.de", "0.0.0.0", 0, 0
CNMI_SETTING=0, 0, 0, 0, 0
SMS_TEXT_MODE=NO
```

17 Configuration of Tones

Tones generated by the RT3000 can be configured by editing the parameter file *tone.ini*. You can access this file in the same way as the parameter file *para.ini*. Refer to page 84.

TONES

In the section TONES The frequencies of all available slic generated tones can be defined. Entering invalid values will provoke the default settings. You can define the following tones:

	Telephone port	default [Hz]	Phone/Fax/Modem port	default [Hz]
Dial tone	CHA_DIAL_TONE	425	CHB_DIAL_TONE	425
Ring back tone	CHA_CALL_CTRL	440	CHB_CALL_CTRL	440
Busy tone	CHA_BUSY_TONE	425	CHB_BUSY_TONE	425
Call wait tone	CHA_CALL_WAIT	440	CHB_CALL_WAIT	440
Programming acceptance tone	CHA_ACPT_PROG	950	CHB_ACPT_PROG	950
Programming non-acceptance tone	CHA_NACPT_PROG	300	CHB_NACPT_PROG	300
PIN last try tone	CHA_PIN_LAST	600	CHA_PIN_LAST	600
SIM missing tone	CHA_SIM_MISS	950	CHB_SIM_MISS	950

Available frequencies are in the range from 300Hz up to 1500Hz in steps of 5Hz.

Example: CHA_DIAL_TONE=425 sets the frequency for the dial tone of channel A to 425 Hz

TONE_LEVEL

In the section TONE_LEVELS, the gain of the generated tones on the SLIC ports can be defined. Following parameters are available in this section for the tone gain on channel a and b.

	Telephone port	default [dB]	Phone/Fax/Modem port	default [dB]
Level	CHA_TONE_LEVEL	0	CHB_TONE_LEVEL	0

Available gains are in range from 0dB down to -30dB in steps of 1dB.

Example: CHA_TONE_LEVEL=0 sets the gain to 0dB for channel A

TIMINGS

In the section TIMINGS the user can define his own tone and ring timings. For the following tones on channel a and b the timings can be changed:

		Sequence definition (default; [ms])					
Telephone port		t1 on	t2 off	t3 on	t4 off	t5 on	Term
RING signal	CHA_RING	100	400	-	-	-	-2
Dial tone	CHA_DIAL	100	0	-	-	-	-2
Ring back tone	CHA_CALL_CTRL	150	350	-	-	-	-2
Busy tone	CHA_BUSY_TONE	50	50	-	-	-	-2
Call wait tone	CHA_CALLWAIT	40	800	16	16	16	-4
Programming acceptance tone	CHA_ACPT_PROG	10	10	-	-	-	-100
Programming non-acceptance tone	CHA_NACPT_PROG	10	50	10	50	-	-100
PIN last try tone	CHA_LAST_PIN	50	50	10	50	-	-4
SIM missing tone	CHA_SIM_MISS	10	50	-	-	-	-2
		Sequence definition (default; [ms])					
Fax/Modem/Phone port		t1 on	t2 off	t3 on	t4 off	t5 on	Term
RING signal	CHB_RING	100	400	-	-	-	-2
Dial tone	CHB_DIAL	100	0	-	-	-	-2
Ring back tone	CHB_CALL_CTRL	150	350	-	-	-	-2
Busy tone	CHB_BUSY_TONE	50	50	-	-	-	-2
Call wait tone	CHB_CALLWAIT	40	800	16	16	16	-4
Programming acceptance tone	CHB_ACPT_PROG	10	10	-	-	-	-100
Programming non-acceptance tone	CHB_NACPT_PROG	10	50	10	50	-	-100
PIN last try tone	CHB_LAST_PIN	50	50	10	50	-	-4
SIM missing tone	CHB_SIM_MISS	10	50	-	-	-	-2

17.1 How to program a new timing

The timing programming sequence consists of the name of the tone, followed by maximal ten on/off-timings and one programming terminator. Timings must be added in parts of 10ms. Valid timings are in range of 0 up to 2 Minutes.

The programming terminator must be added to the end of the timing sequence. Programming terminators always have negative values. The value '-100' is a fixed value to define the end of a non repeatable sequence. If there's a '-100' at the end of the timing sequence, it signalises, that it's the end of the sequence and no repeat is wanted. Other values define, how many steps in the sequence the tone generator has to go back. At this place in the timing sequence, the tone generator has to go.

For better understanding, how to program a new timing or how to modify an existing timing, have a look at the following examples:

- **Example 1: RING sequence on channel b**

CHB_RING=100,400,-2

- 100 = ring on for $100 \cdot 10\text{ms} = 1\text{s}$
- 400 = ring off for $400 \cdot 10\text{ms} = 4\text{s}$
- -2 = timing sequence terminator. Go 2 steps back in timing sequence -> next timing is a ring on with $100 \cdot 10\text{ms}$ again

- **Example 2: CALLWAIT on channel b**

CHB_CALLWAIT=40,800,16,16,16,-4

- 40 = tone on for $40 \cdot 10\text{ms} = 400\text{ms}$
- 800 = tone off for $800 \cdot 10\text{ms} = 8\text{s}$
- 16 = tone on for $16 \cdot 10\text{ms} = 160\text{ms}$
- 16 = tone off for $16 \cdot 10\text{ms} = 160\text{ms}$
- 16 = tone on for $16 \cdot 10\text{ms} = 160\text{ms}$
- -4 = timing sequence terminator. Go 4 steps back in timing sequence -> next timing is the tone off for $800 \cdot 10\text{ms}$

- **Example 3: NON_ACCEPT_PROGRAMMING on channel b**

CHB_NON_ACPT_PROG=10,50,10,50,-100

- ➔ 10 = tone on for $10 \times 10\text{ms} = 100\text{ms}$
- ➔ 50 = tone off for $50 \times 10\text{ms} = 500\text{ms}$
- ➔ 10 = tone on for $10 \times 10\text{ms} = 100\text{ms}$
- ➔ 50 = tone off for $50 \times 10\text{ms} = 500\text{ms}$
- ➔ -100= timing sequence terminator. This timing sequence ends here. Tone generators stops with the actual (tone off) setting

All programmed timings, levels and frequencies were read from TONE.INI only once at the start up of the device. After changes have been made, a reset of the device must be done, to use them.

17.2 Example-File:

```
;RT-XNG Tone-Parameter File
[TONES]
;settings for channel a
CHA_DIAL_TONE=425
CHA_CALL_CTRL=440
CHA_BUSY_TONE=425
CHA_CALL_WAIT=440
CHA_ACPT_PROG=950
CHA_NACPT_PROG=300
CHA_PIN_LAST=600
CHA_SIM_MISS=950
;settings for channel b
CHB_DIAL_TONE=425
CHB_CALL_CTRL=440
CHB_BUSY_TONE=425
CHB_CALL_WAIT=440
CHB_ACPT_PROG=950
CHB_NACPT_PROG=300
CHB_PIN_LAST=600
CHB_SIM_MISS=950

[TONE_LEVEL]
;level range -> 0dB <-> -30 dB
```

CHA_TONE_LEVEL=0

CHB_TONE_LEVEL=0

[TIMINGS]

;*#index0=on, index1=off, index2=on, index3=off...*

;*timing-sequence-terminators: -100 -> end of sequence; -2 -> 2 steps back; -4 -> 4 steps back ...*

;*settings for channel a*

CHA_RING=100,400,-2

CHA_DIAL=100,0,-2

CHA_CALL_CTRL=150,350,-2

CHA_BUSY=50,50,-2

CHA_CALLWAIT=40,800,16,16,16,-4

CHA_ACPT_PROG=10,10,-100

CHA_NON_ACPT_PROG=10,50,10,50,-100

CHA_LAST_PIN=50,50,10,50,-4

CHA_MISS_SIM=10,50,-2

;*settings for channel b*

CHB_RING=100,400,-2

CHB_DIAL=100,0,-2

CHB_CALL_CTRL=150,350,-2

CHB_BUSY=50,50,-2

CHB_CALLWAIT=40,800,16,16,16,-4

CHB_ACPT_PROG=10,10,-100

CHB_NON_ACPT_PROG=10,50,10,50,-100

CHB_LAST_PIN=50,50,10,50,-4

CHB_MISS_SIM=10,50,-2

[GENERAL]

VERSION_TONE_INI=1.018

18 Logfile

Relevant events of the RT3000 are reported in a Logfile. You can access this Logfile in the same way as the parameter file *para.ini*. Refer to page 84.

The name of the Logfile is:

logfile.\$rf

Close the FTP connection after the Logfile is copied to your PC. You can open the Logfile using a standard text editor.

A logfile entry has the following format:

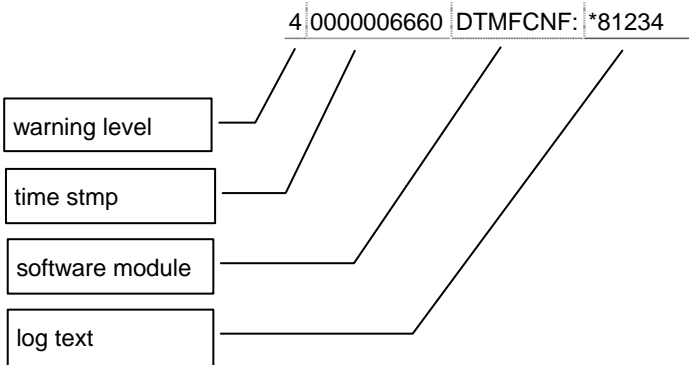

Meaning:

Warning level	Errors are on lower levels (e. g. level 1), information about normal events are on a higher level (e. g. level 4).
Time stamp	The time this logfile entry is written
Software module	The software module that has generated this logfile entry
Log text	Description of the event.

19 Update the firmware

The firmware of the RT3000 can be updated using a local connected PC (connected to the USB or RS-232 port) or from remote.

The approach is just as if you want to configure the SAGEM RT3000 by uploading the edited configuration file *para.ini* by FTP - see *15.3 Configuration by FTP (Local and Remote)*, page 84.

- The configuration data call must be initiated from a station whose telephone number is configured in the REMOTE_ACCESS Section of the parameter file "para.ini" (see *Settings for the configuration access via SMS and FTP*, page 87).

The Firmware update is done via FTP (local or remote):

Upload the file „rt3000.bin“ to the SAGEM RT3000.

Upload the file „!cmdfile“ (filename without extension) to the SAGEM RT3000.

The file *!cmdfile* is a text file (plain text) containing the following command:
STORE rt3000.bin

- Please make sure that the filename is simply *!cmdfile* without an extension.

After uploading the files the SAGEM RT3000 will reboot.

This procedure may take several minutes.

You may check the completion of the download as follows:

Via FTP you can download the file „!cmdlog“. After successful completion of the firmware update it has the following contents:

```
>> STORE rt3000.bin
<< OK
```

OR

Enter the command AT19 at the PC interface of your terminal program when you have a data connection to the SAGEM RT3000. The new version number should be displayed.

20 Connection sockets

RJ12 "PHONE" socket

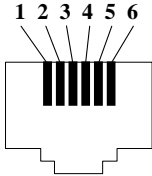

Pin 3: LA
 Pin 4: LB
 The other pins are not used.

RJ12 "FAX/MODEM/PHONE" socket

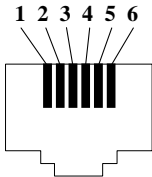

Pin 3: LA
 Pin 4: LB
 The other pins are not used.

USB Interface

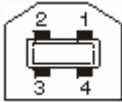

Pin	Signal
1	+5 V
2	USBP0- [USBP1-]
3	USBP0+ [USBP1+]
4	GND (ground)

Serial interface DB-9-F

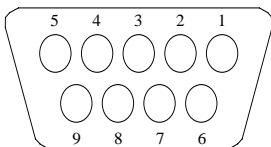

Pin	ITU-T	DIN	EIA	USA	Designation
1	109	M5	CF	DCD	Carrier Detect
2	104	D2	BB	RXD	Received Data
3	103	C1	BA	TXD	Transmitted Data
4	108.2	S1.2	CD	DTR	Device Ready
5	102	E2	AB	GND	Operating Ground
6	107	M1	CC	DSR	Modem Ready
7	105	S2	CA	RTS	Request To Send
8	106	M2	CB	CTS	Modem Ready to Send
9	125	M3	CE	RI	Incoming Call

The serial interface is operated at a data rate of 57600 bps.
 The data format is 8-N-1 (8 data bits, no parity bit, 1 stop bit).

21 Technical data

Analogue interfaces	2 interfaces RJ11 (a/b-lead), one for analogue telephones, one for analogue telephones, fax machine, modem. max. 5 REN for all telecomms equipment connected to the RT3000
Digital interfaces	USB (Client); RS-232 (ITU V.24/V.28); Data rates: 300 – 115.200 bit/s; Communication: PC-Fax, PC-SMS, PC-Data (CSD and GPRS)
Supplementary Services	Call waiting, Call barring, Call forward, CLIP, CLIR, 3-Party-Call, depending on network
Dialling	DTMF and Pulse dialling
Port options	Polarity Reversal; Billing pulses (12kHz; 16kHz; for Voice calls)
Analogue fax	Support of Group 3 Fax machines, 9600 bit/s (V.29)
PC fax	AT command set TR29 Class 1
Analogue modem	Data rates 300,1.200,2.400,4.800,9.600 bit/s (V.21,V.22,V.22bis,V.32) MNP2 flow control
PC data	GPRS: Multislot class 10; class B terminal, coding schemes: CS-1, CS-2, CS-3, CS-4; PBCCH support CSD: 300,1.200,2.400,4.800,9.600 bit/s; AT command set ; 9.600 bit/s, RLP
PC SMS	AT command set; MO/MT/CB
Voice codecs	Fullrate, Enhanced Fullrate, Halfrate
Transmit power	EGSM 900 MHz (2 Watt), DCS 1800 MHz (1 Watt), GSM 850 MHz (2 Watt), PCS 1900 MHz (1 Watt)
Antenna interface	Impedance: 50 Ohm (nominal); Connector: TNC
Power supply	Mains: 230 VAC 50Hz or 110 230 VAC 50/60Hz Input 12 - 24 VDC (Battery backup requires min. 17 VDC)
Battery backup	Regular Autonomy Version: Battery backup up to 2h operation time / 8h stand-by time rechargeable High Autonomy Version: Battery backup up to 4,5h operation time / 15h stand-by time rechargeable
Environment	Temperature range -10° bis +55° C Humidity 0-95%, not condensing
Compliance	CE (Residential, commercial and light-industrial-environment); R&TTE (GSM); GSM/GPRS-Module compliant to GCF and PTCRB; Safety according to EN 60950
Dimensions	ca.195 x 151 x 38 mm (L x W x H) ca. 620g (incl. battery and antenna)